



PLASSON

2024

ELECTROFUSION FITTINGS

Milder

Veelzijdig in leidingsystemen

Introduction Introducción

Electrofusion System	96	Sistema ElectroFusión	97
Table of Contents	98-102	Indice	98-102
Fittings	103-153	Accesorios	103-153
Wastewater Line	154-159	Aguas residuales	154-159
Technical Specifications	160	Especificaciones técnicas	161

PLASSON, a worldwide leader in fittings for polyethylene pipes for over 50 years, now offers a complete line of electrofusion products including: PLASSON electrofusion fittings, tools and control boxes.

PLASSON electrofusion products combine to offer a reliable smart-system solution featuring fully computerized control and monitoring.

PLASSON's customers benefit from the Company's quality products, expertise and worldwide first-rate service in water, gas distribution, Waste-Water Systems, Geothermal applications and industrial applications.

PLASSON, líder mundial en accesorios para tuberías de polietileno desde hace más de 50 años, presenta ahora una línea completa de productos de electrofusión, entre ellos: conectores, herramientas y soldadoras automáticas de electroFusión. La combinación de productos electrofusion de PLASSON ofrece una solución inteligente y confiable que integra el control y la monitorización completamente computarizados.

Los clientes de PLASSON se benefician de los productos de calidad, la pericia y el excelente servicio mundial de la compañía en instalaciones de distribución de agua y gas, y aplicaciones industriales.

Subsidiary Companies Subsidiarias

Australia

PLASSON Australia (PTY) Ltd.
E-mail: info@plasson.com.au
www.plasson.com.au

Brasil

PLASSON Do Brasil
E-mail: plasson@plasson.com.br
www.plasson.com.br

France

PLASSON France S.A.
E-mail: commercial@plassonfrance.fr
www.plasson.fr

Germany

PLASSON GmbH
E-mail: info@plasson.de
www.plasson.de

Italy

PLASSON Italia
E-mail: info@plasson.it
www.plasson.it

Poland

PLASSON Polska Sp.z o.o.
E-mail: bs@plasson.pl
www.plasson.pl

South Africa

PLASSON SA Pty Ltd, t/a PPA
E-mail: support@ppa.co.za
www.ppa.co.za

Spain

PLASSON Spain S.L.
E-mail: plasson@plasson.es
www.plasson.es

United Kingdom

PLASSON UK Ltd.
E-mail: miron@plasson.co.uk
www.plasson.co.uk

USA

PLASSON USA
E-mail: sales@plassonusa.com
www.plassonusa.com

Romania

PLASSON Romania (BSR)
E-mail: contact@bsr.ro
www.plasson.ro

PLASSON Electrofusion System

The Smart-System Solution You Can Depend On

PLASSON Electrofusion Fittings

PLASSON fittings are specifically designed for reliable, high performance pipe joining and long system life. This automated system has been proven to be most economical due to the low potential for operator error.

Tools and Control Box

PLASSON offers quality tools and control boxes allowing for easy installation. PLASSON control boxes provide computerized electrofusion with minimal potential for operator error. The PLASSON control boxes are the economical solution for reliable electrofusion.

The Smart Fuse System - PLASSON Electrofusion

All PLASSON products combine to form the latest state-of-the-art high performance pipe joining solution. PLASSON electrofusion fittings are part of a complete electrofusion Smart Fuse System. The entire electrofusion process is executed and fully monitored by the computerized control box. Everything is computer-controlled ensuring safe, dependable connections.

PLASSON electrofusion fittings can be used with PLASSON's computerized Smart Fuse System control box or with standard barcode systems. Each PLASSON electrofusion fitting comes complete with a barcode.

Advantages

Stronger pipe joining - PLASSON electrofusion quality fittings have long penetration depths and fusion zones which ensure high quality joints.

Most Economical - Economic benefits are a result of overall integrated system quality and innovation including the computerized Smart Fuse System which reduces the potential for operator error.

PLASSON Electrofusion Smart Fuse System Features

- **Superior Fitting Design**
increases joint integrity
- **Automatic Controller**
decreases potential operator error
- **Computerized Data Retrieval**
ensures quality control by Joint Data retrieval of measurements and records
- **Compatibility**
between PLASSON electrofusion and other electrofusion systems through the computerized barcode system
- **Easy Installation**
using PLASSON's simple, practical tools
- **High Standards**
are ensured by the latest product testing methods

High Performance - Proven high performance in gas and water distribution and industrial applications.

Superior Service - PLASSON provides unmatched service based on over 40 years in the field.

Sistema Electrofusion de PLASSON

La solución inteligente de confianza

Accesorios Electrofusion de PLASSON

Los accesorios ("fittings") de PLASSON para tuberías han sido especialmente diseñados para asegurar conexiones fiables, de alto rendimiento y prolongada vida útil. Se ha comprobado que este sistema automatizado es el más económico, gracias a la escasa probabilidad de errores por parte del operador.

Herramientas y soldadora automática de ElectroFusión

PLASSON ofrece herramientas de alta calidad y soldadoras automáticas que se instalan fácilmente. Las soldadoras, que proporcionan un proceso computarizado con mínima probabilidad de error humano, son la solución más económica para una electrofusión de máxima confianza.

Electrofusion de PLASSON - El sistema inteligente

Los productos de PLASSON se combinan para ofrecer la solución más avanzada y rendidora en la conexión de tuberías. Los accesorios electrofusion de PLASSON forman parte de un sistema completo e inteligente. La soldadora automática de ElectroFusión está a cargo de la ejecución y la monitorización del proceso. El sistema controlado por computadora asegura conexiones seguras y confiables.

Ventajas

Uniones más resistentes - Los accesorios de alta calidad electrofusion de PLASSON tienen grandes profundidades de penetración y zonas de fusión que aseguran juntas muy resistentes.

La solución más económica - El beneficio económico es el resultado de la calidad y la innovación del sistema computarizado totalmente integrado, que reduce la probabilidad de error humano.

Características del sistema inteligente Electrofusion de PLASSON

- **Excelente diseño**
asegura la integridad de la conexión
- **Control automático**
reduce la probabilidad de error humano
- **Recuperación de datos**
calidad asegurada mediante la recuperación de datos de mediciones y registros
- **Compatibilidad**
con el sistema electrofusion de PLASSON y otros sistemas de códigos de barras
- **Instalación sencilla**
mediante las herramientas prácticas y simples de PLASSON
- **Estándar elevado**
asegurado por los métodos de prueba de productos de última generación

Alta performance - Elevado rendimiento comprobado en instalaciones de distribución de gas y agua, y aplicaciones industriales.

Excelente servicio - PLASSON le brinda un servicio inigualado, con su pericia y experiencia de más de 40 años en el terreno.

Fittings

490104/490103

Page 103 | Coupler
Enlace Recto



4901L4

Page 104 | Long Coupler
Enlace Largo



450104

Page 104 | Coupler (PN 25)
Enlace Recto (PN 25)



460104/460103

Page 106 | LightFit Coupler (PN 10)
Enlace LightFit (PN 10)



4601S3

Page 107 | Super LightFit (PN 6.4)



491104

Page 107 | Reducing Coupler
Enlace Reductor



491107

Page 108 | Spigot Reducer
Reductor Espiga



49009

Page 109 | Flex Restraint



494204

Page 110 | Monolithic End Cap
Tapón Monolítico



491204

Page 110 | End Cap
Tapón



491207

Page 111 | Spigot End Plug
Tapón Espiga



490404

Page 113 | Tee 90°
Enlace T 90°



492404

Page 113 | Two Outlets Reducing Tee
Enlace te Reductor con Salida Doble



491404

Page 114 | Reducing Tee
Enlace T Reductor



499404

Page 115 | Flanged Tee
Enlace T Bridado



490504

Page 115 | Elbow 90°
Codo 90°



490604

Page 116 | Elbow 45°
Codo 45°



490804

Page 116 | Elbow 22.5°
Codo 22.5°



46060

Page 117

LightFit Elbow 45°
Codo LightFit 45°



46330

Page 117

LightFit Elbow 30°
Codo LightFit 30°



46370

Page 117

LightFit Elbow 15°
Codo LightFit 15°



490904

Page 118

Elbow 180°
Codo 180°



491904

Page 118

Y Reducer
Y Reductor



491504

Page 119

Duckfoot Elbow 90°
Codo 90° Empotrable



4915Q4

Page 119

Duckfoot Elbow 90° with Outlet
Codo 90° Empotrable con
Toma de Servicio



4947C4

Page 120

Adjustable Elbow
Codo Ajustable



4947D4

Page 120

Adjustable Elbow One Sided
Codo Ajustable Enlace/
Espiga



496804

Page 121

Balloon Saddle
Collarín Globo



498304

Page 121

Monolithic Weld End Cap for
Ballon Saddle
Tapón Monolítico Soldable
para Collarín Globo



4958T4

Page 122

Saddle Female Rp
Threaded Outlet



495204

Page 122

Repair Saddle
Toma de Reparación



493804

Page 123

Transition Saddle
Collarín de Transición



493803

Page 126

Sensor Adaptor with Brass
Thread



4938S3

Page 126

Sensor Adaptor with a
Stainless Steel thread



495804

Page 127

Branch Saddle
Collarín de Derivación



495804

Page 128

Branch Saddle
Collarín de Derivación



4958X4

Page 128

Branch Saddle



495803

Page 130-131

XL&XXL Branch Saddle
XL&XXL Collarín de Derivación



4758W

Page 131

LightFit Branch Saddle
Collarín de Derivación LightFit



495904

Page 132

Flange Branch Saddle
Collarín bridado



4959X4

Page 133

Flanged Branch Saddles
DN100
Collarín Bridado DN 100



495204

Page 133

Repair Saddle
Collarín de reparación



496304

Page 134-135

Tapping Saddle
Toma de Servicio



4963P4

Page 136

Tapping Saddle Parallel Outlet
Toma de Servicio Salida Parallel
Outlet



491304

Page 137

High Volume Tapping Tee
(HVTT)



498304

Page 137

Welding Cap for Tapping Saddle
Tapón Soldable para toma de Servicio



436207

Page 138

PE Ball Valve
Válvula de Bola PE



436Q7

Page 138

PE Ball Valve with
Two Purges
PE Ball Válvula de
Bola con purga



495404/4954S4

Page 139

Tapping Valve
Toma de Servicio con
Válvula



4921N4

Page 141

PA Male Transition Coupler
PA Enlace de Transición
Macho



4921N7

Page 142

PA Male Transition Adaptor
PA Adaptador de Transición
Macho



4925N4

Page 143

90° PA Male Elbow



4926N4

Page 143

45° PA Male Elbow



492104

Page 144

Male Transition Coupler
Enlace de Transición Macho



493104

Page 144

Female Transition Coupler
Enlace de Transición
Hembra



492504

Page 145

Male Transition Elbow 90°
Codo de Transición de 90°
Macho



493504

Page 146

Female Transition Elbow 90°
Codo de Transición de 90°
Hembra



492604

Page 146

Male Transition Elbow 45°
Codo de Transición de 45°
Macho



493604

Page 147

Female Transition Elbow 45°
Codo de Transición de 45°
Hembra



494104

Page 147

Female Free Nut
Transition Coupler
Enlace de Transición,
Tuerca Libre, Hembra



494504

Page 148

Female Free Nut
Transition Elbow 90°
Codo de Transición de 90°
Tuerca Libre, Hembra



494604

Page 148

Female Free Nut Transition
Elbow 45°
Codo de Transición de 45°
Tuerca Libre, Hembra



494404

Page 149

Female Union Free Nut
Transition Tee
Enlace T, PE/Latón, Tuerca
Libre, Hembra



497104

Page 149

PE Male Transition Coupler
Enlace de Transición PE
Macho



497504

Page 150

PE Male Transition Elbow 90°
Codo de Transición PE de 90°
Macho



497604

Page 150

PE Male Transition Elbow 45°
Codo de Transición PE de 45°
Macho



497704

Page 151

PE Cast Iron Flange
Transition Coupler
Enlace de Transición
Bridado - PE Hierro Fundido



495704

Page 151

PE Cast Iron Spigot
Transition Coupler
Enlace de Transición Espiga
- PE Hierro Fundido



490209

Page 152

Full Face Flange
Brida de Cara Plana



490207

Page 152

Stub Flange
Adaptador de Brida



09903

Page 153

Flange Backing Ring
Brida Revestida



Wastewater Line

475804

Page 155

Wastewater Adjustable Saddle
Ramal para Aguas Residuales



4758A4

Page 155

Wastewater Saddle 45° - Inlet 110
Ramal 45° de Salida para Aguas Residuales



4758V4

Page 156

Wastewater Saddle PVC/PP Adaptor Inlet
Collarin Lightfit de transicion para Aguas Residuales de PE A PP/PVC



4758S4

Page 156

Wastewater Saddle Spigot Inlet
Titulo



4747D4

Page 157

Wastewater Adjustable Elbow One Sided
Codo Ajustable para Aguas Residuales Enlace/Espiga



37020/477207

Page 157

Wastewater Manhole Adaptor
Adaptador para Pozo de Aguas Residuales



4701V4

Page 158

Wastewater PE to PVC Adaptor
Adaptador Para PE A PVC



4747V4

Page 158

Wastewater Adjustable Elbow PE to PVC
Codo Ajustable de Transición de PE a PVC



470604

Page 159

Wastewater Elbow 45°
Codo 45° Para Aguas Residuales



473304

Page 159

Wastewater Elbow 30°
Codo 30° Para Aguas Residuales



473704

Page 159

Wastewater Elbow 15°
Codo 15° Para Aguas Residuales



Coupler

490104

Enlace Recto



20mm up to 75mm

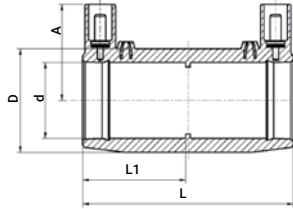

90mm up to 355mm

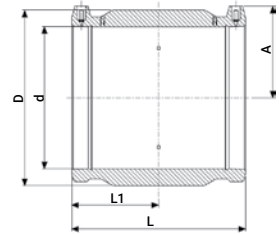

Product Code	Size d	L	L1	D	A	UC	W
490104016	16	71	34	35	39	480	58
490104020	20	76	37	31	34	440	50
490104025	25	82	40	36	37	360	40
490104032	32	88	42	44	42	256	64
490104040	40	97	47	56	46	200	97
490104050	50	101	49	67	51	125	160
490104063	63	118	58	82	56	72	230
490104075	75	126	61	98	64	60	340
490104090	90	148	73	112	71	38	475
490104110	110	163	80	135	81	23	718
490104125	125	173	85	157	87	18	1075
490104140	140	183	90	174	97	12	1295
490104160N	160	195	93	194	105	6	1555
490104180N	180	212	105	218	116	5	2112
490104200N	200	223	109	242	126	4	2785
490104225N	225	240	119	272	138	4	3900
490104250	250	251	123	301	156	2	4461
490104280	280	275	134	342	170	1	6440
490104315	315	282	139	387	184	1	8845
490104355	355	277	137	431	203	1	10200
490103400	400	293	145	485	231	1	13800

490103

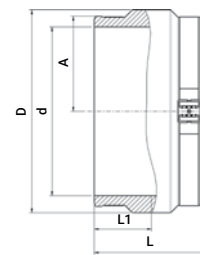

Product Code	Size d	L	L1	D	A	UC*	W
490103450	450	306	153	539	257	1	16000
490103500	500	340	170	603	283	1	20200
490103560	560	376	188	674	317	1	28000
490103630N	630	418	209	759	356	1	41100
490103710	710	472	236	853	400	1	62000
490103800	800	500	250	955	450	1	87000
490103900	900	500	250	1070	503	1	100100
4901031000	1000	570	285	1194	563	1	

* Due to product size, cannot be packed in standard carton | * Cantidad óptima para embalaje en dos pallets apilados

Long Coupler

4901L4

Enlace Largo

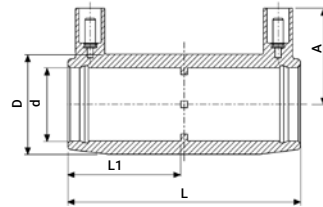

Product Code	Size d	L	L1	D	A	UC	W
4901L4032	32	104	50	44	43	272	83
4901L4040	40	121	59	56	46	128	135
4901L4050	50	139	68	68	51	96	215
4901L4063	63	166	81	82	57	48	318

Coupler (PN 25)

450104

Enlace Recto (PN 25)

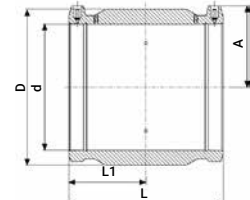
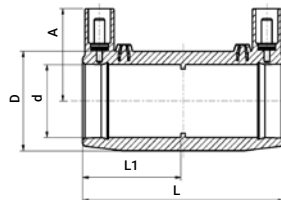

Product Code	Size d	L	L1	D	A	UC	W
450104050	50	100	49	68	52	125	147
450104063	63	118	57	82	58	72	230
450104075	75	126	62	97	65	60	339
450104090	90	148	73	117	69	38	571
450104110	110	163	80	140	79	23	835
450104125	125	173	85	157	87	18	1075
450104140	140	105	175	181	89	12	1320
450104160	160	198	97	198	105	6	1780
450104180	180	212	104	224	114	4	2449
450104200	200	223	110	249	126	4	3295
450104225	225	240	118	280	140	4	4366
450104250	250	256	127	310	155	2	5507
450104280	280	274	135	341	166	1	6369
450104315	315	284	140	381	184	1	8884
450103355	355	280	138	430	204	1	10438



PLASSON Excess Flow Valve

The Excess Flow Valve (EFV), also called Gas Stop, is a special safety valve intended to be used in the house connection line of natural or other gas systems. It is typically installed at the outlet of the tapping saddle at the branch off point or on the house connection line, but can be installed at other locations and applications as well.

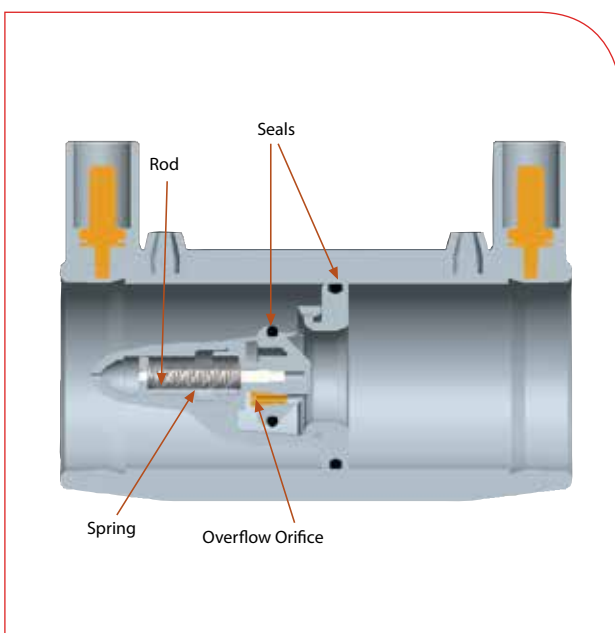
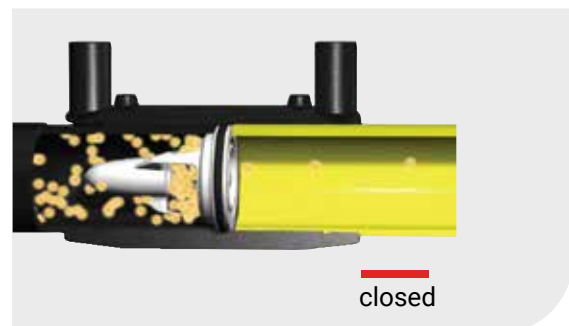
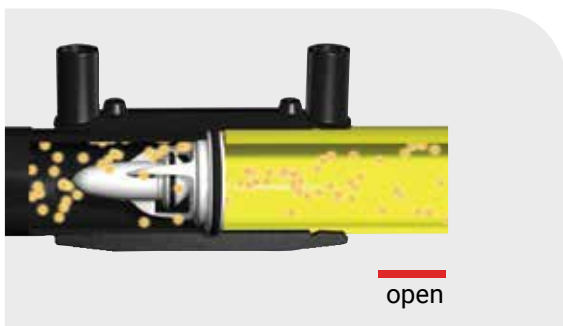

Design Features:

- Fully mechanical
- Unique design results in very low head loss at operation flow
- Easy installation

Components and Materials:

- Plastic Parts – PolyAcetal (POM-thermoplastic polymer)
- Rod – Stainless Steel or Brass (depending on model)
- Overflow Orifice - Brass
- Spring – Stainless Steel
- Seals – NBR

Application

- In PE Gas Conducting Systems

LightFit Coupler (PN10)

460104

Enlace LightFit (PN10)

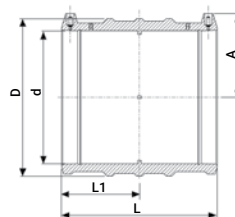

Product Code	Size d	L	L1	D	A	UC	W
460104040	40	90	43	56	47	200	96
460104050	50	100	49	68	52	132	147
460104063	63	118	57	77	57	112	158
460104075	75	126	61	90	63	60	216
460104090	90	148	72	108	69	44	360
460104110	110	163	80	131	79	25	540
460104125	125	173	85	149	87	20	760
460104140	140	182	89	167	94	12	970
460104160	160	198	97	193	104	6	1320
460104180	180	212	104	215	114	5	1650
460104200	200	232	114	235	127	4	2110
460104225	225	240	118	264	141	4	2825
460104250	250	256	126	293	155	2	3728
460104280	280	275	135	332	166	1	4850
460104315	315	284	140	374	184	1	6950
460104355	355	280	138	421	204	1	7980
460104400	400	296	146	474	227	1	12000

460103*



Product Code	Size d	L	L1	D	A	UC*	W
460103450N	450 **	310	155	518	255	1	11700
460103500	500**	340	170	576	283	1	16000
460103560N	560	376	188	625	309	1	21510
460103630N	630	400	200	706	347	1	27000
460103710N	710	440	220	797	390	1	43100
460103800N	800	470	235	897	440	1	57300
460103900	900	500	250	1010	500	1	70000
4601031000	1000	600	300	1128	555	1	-
4601031200	1200	600	300	1355	667	1	-

* Due to product size, cannot be packed in standard carton | * Cantidad óptima para embalaje en dos pallets apilados

** Without Straps | ** Sin correas

Super LightFit (PN 6.4)

4601S3

Super LightFit (PN 6.4)

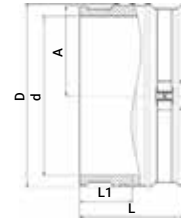

Product Code	Size d	L	L1	D	A	UC*	W
4601S3500	500	300	150	550	272	1	11800
4601S3560	560	310	155	620	310	1	15300
4601S3630	630	320	160	693	346	1	18200
4601S3710	710	380	190	775	388	1	25800
4601S3800	800	400	200	876	438	1	34700
4601S3900	900	420	210	983	485	1	40500
4601S31000	1000	440	220	1085	534	1	48000

* Due to product size, cannot be packed in standard carton | * Cantidad óptima para embalaje en dos pallets apilados.

Reducing Coupler

491104

Enlace Reductor

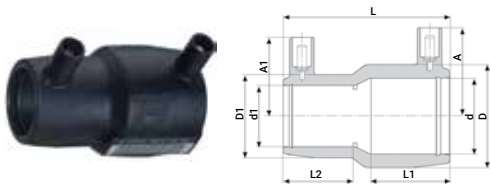

20x16mm up to 110x90mm

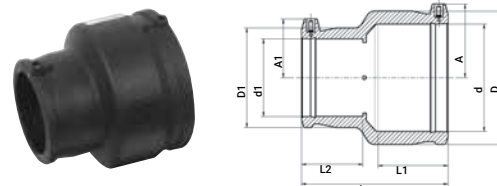

125x90mm up to 180x125mm

Product Code	Size dxd1	L	A	A1	L1	L2	D	D1	UC	W
491104020016	20 x 16	71	39	39	35	35	36	36	480	54
491104025016	25 x 16	71	38	38	35	35	36	36	480	49
491104025020	25 x 20	71	39	39	35	35	36	36	480	46
491104032016	32 x 16	80	42	34	39	35	44	32	360	58
491104032020	32 x 20	81	43	37	40	35	45	32	360	59
491104032025	32 x 25	81	43	39	40	35	45	36	360	56
491104040020	40 x 20	90	44	38	44	40	56	36	360	58
491104040025	40 x 25	90	47	38	44	40	56	37	200	86
491104040032	40 x 32	90	47	43	44	40	56	44	160	92
491104050025	50 x 25	100	52	41	49	41	68	37	160	118
491104050032	50 x 32	100	52	45	49	40	68	45	128	123
491104050040	50 x 40	100	52	48	49	44	68	56	128	135
491104063032	63 x 32	119	59	45	57	40	82	45	96	180
491104063040	63 x 40	119	59	49	57	44	82	56	96	192
491104063050	63 x 50	119	59	54	57	49	82	68	80	224
491104075063	75 x 63	126	66	59	66	57	98	82	65	314
491104090050	90 x 50	143	78	53	71	49	116	69	54	430
491104090063	90 x 63	143	78	61	71	57	116	82	44	460
491104090075	90 x 75	143	78	67	71	61	116	98	41	480
491104110063	110 x 63	161	84	61	78	57	139	82	32	639
491104110075	110 x 75	159	83	66	80	62	140	98	-	-
491104110090	110 x 90	161	84	74	78	72	139	116	23	740
491104125090	125 x 90	171	88	70	85	72	158	116	18	1019
491104125110	125 x 110	171	88	80	85	78	158	141	18	1025
491104160090	160 x 90	193	105	69	94	72	199	116	12	1440
491104160110	160 x 110	193	105	80	94	81	199	141	12	1520
491104160125	160 x 125	195	105	89	94	85	199	158	6	1570
491104180125	180 x 125	212	116	87	103	85	222	158	6	2060

Spigot Reducer

491107

Reductor Espiga

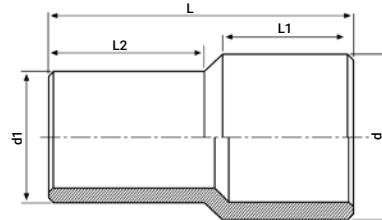

Product Code	Size dxd1	L	L1	L2	UC	W
491107032025	32 x 25	104	50	48	240	30
491107040032	40 x 32	123	59	56	240	90
491107050032	50 x 32	129	59	56	160	100
491107050040	50 x 40	131	59	60	264	80
491107063032	63 x 32	131	59	58	144	110
491107063040	63 x 40	132	59	58	144	120
491107063050	63 x 50	132	60	60	128	125
491107075040	75 x 40	145	71	60	96	167
491107075050	75 x 50	145	71	59	96	180
491107075063	75 x 63	151	71	65	72	210
491107090050	90 x 50	156	81	59	56	280
491107090063	90 x 63	160	80	65	48	300
491107090075	90 x 75	166	80	71	40	320
491107110063	110 x 63	167	83	66	36	450
491107110075	110 x 75	169	83	72	36	460
491107110090	110 x 90	178	83	80	28	510
491107125090	125 x 90	186	90	81	24	655
491107125110	125 x 110	188	90	84	18	730
491107140090	140 x 90	208	95	80	16	850
491107140110	140 x 110	195	95	83	16	850
491107140125	140 x 125	199	95	89	12	950
491107160110	160 x 110	219	101	84	10	1,360
491107160125	160 x 125	206	101	88	16	1170
491107160140	160 x 140	211	101	94	10	1270
491107180125	180 x 125	221	107	89	10	1500
491107180140	180 x 140	224	107	95	10	1600
491107180160	180 x 160	225	107	100	8	1750
491107200140	200 x 140	229	114	93	8	2200
491107200160	200 x 160	233	115	100	6	2,420
491107200180	200 x 180	241	116	106	5	2350
491107225160	225 x 160	295	132	123	—	3,100
491107225180	225 x 180	285	130	118	—	3,190
491107225200	225 x 200	272	126	120	—	3,700
491107250160	250 x 160	308	149	100	—	4,100
491107250180	250 x 180	316	151	105	—	4,000
491107250200	250 x 200	324	151	116	—	4,200
491107250225	250 x 225	330	155	122	—	4,700
491107280200	280 x 200	345	140	116	—	11,700
491107280225	280 x 225	335	142	122	—	6,090
491107280250	280 x 250	340	139	135	—	6,500
491107315225	315 x 225	365	150	125	—	8,000
491107315250	315 x 250	365	147	134	—	8,000
491107315280	315 x 280	365	150	145	—	9,000
491107355250	355 x 250	390	164	136	—	11,800
491107355280	355 x 280	390	164	139	—	13,150
491107355315	355 x 315	390	164	150	—	13,000
491107400280	400 x 280	415	179	139	—	17,400
491107400315	400 x 315	415	179	150	—	17,200
491107400355	400 x 355	420	179	164	—	17,800

Maximum Pressure: PN 16 (cold water) | Presión Máxima: PN 16 (agua fria)
 Additional dimensions and pressure rated spigots are available upon request
 Los tamaños y presiones no enunciados en la tabla están disponibles a pedido

Flex Restraint

49009

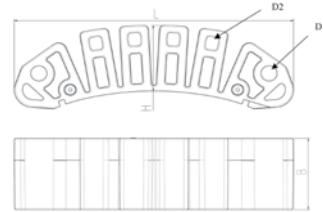

Product Code	Size	L	H	B	D1	D2	UC	W
49009998	160-1600	237	60	65	13.5	11	48	470

* See dedicated tools on page 187 | * Ver herramientas necesarias en pag.187

Flex Restraint

49009

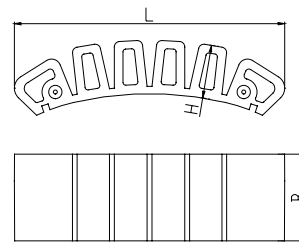

Product Code	Size	L	H	B	UC	W
49009999	140-1600	202	40	65	60	300

* See dedicated tools on page 187 | * Ver herramientas necesarias en pag. 187

Monolithic End Cap

494204

Tapón Monolítico

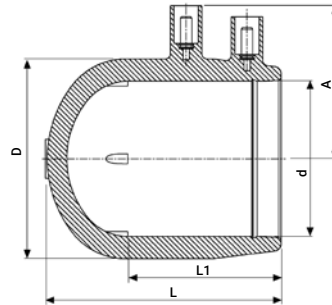

Product Code	Size d	L	L1	D	A	UC	W
494204032	32	63	44	44	46	432	50
494204040	40	70	48	55	51	256	75
494204050	50	82	55	68	56	192	122
494204063	63	95	62	81	62	96	182

End Cap

491204

Tapón

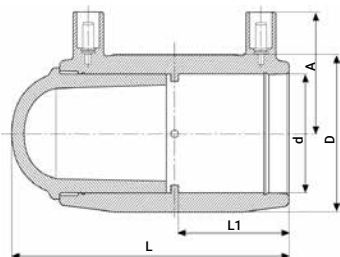

20mm up to 75mm

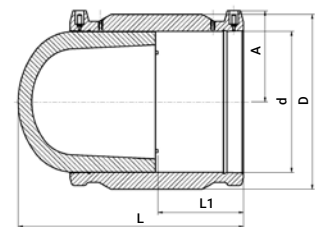

90mm up to 315mm

Product Code	Size d	L	L1	D	A	UC	W
491204020	20	84	37	31	34	400	55
491204025	25	92	40	36	37	400	50
491204032	32	103	42	44	42	300	76
491204040	40	114	47	56	46	160	130
491204050	50	121	49	67	51	120	204
491204063	63	142	57	82	57	72	327
491204075	75	156	61	98	64	48	499
491204090	90	183	73	117	70	30	820
491204110	110	206	78	140	81	20	1259
491204125	125	222	85	157	87	15	1702
491204140	140	237	90	174	97	10	2346
491204160	160	261	93	194	105	6	2990
491204180	180	283	105	218	116	5	4159
491204200	200	289	109	242	126	4	5260
491204225	225	318	119	272	138	2	7260
491204250	250	344	123	311	156	1	8381
491204280	280	396	134	340	170	1	11740
491204315	315	405	139	387	184	2*	16045

* Due to product size, cannot be packed in standard carton | * Cantidad óptima para embalaje en dos pallets apilados

Spigot End Plug

491207

Tapón Espiga

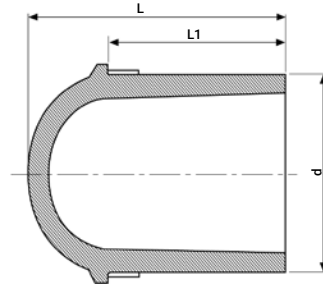

Product Code	Size d	L	L1	UC	W
491207020	20	43	35	2000	8
491207025	25	46	36	1600	10
491207032	32	52	39	960	17
491207040	40	59	43	560	29
491207050	50	68	48	352	52
491207063	63	81	57	192	95
491207075	75	90	60	132	149
491207090	90	105	70	72	250
491207110	110	121	78	57	430
491207125	125	131	82	36	596
491207140	140	142	87	25	797
491207160	160	157	94	18	1149
491207180	180	172	101	14	1600
491207200	200	178	112	10	2089
491207225	225	196	120	6	2800
491207250	250	216	130	4	3920
491207280	280	257	162	3	5300
491207315	315	262	167	2	7200



PE-RT: Polyethylene of Raised Temperature Resistance



PE-RT is a grade of high density polyethylene which has improved Long Term Hydrostatic Strength (LTHS) at elevated temperatures, making it suitable for use in various hot water applications:

- Hot and cold water installations within buildings for central heating systems and potable water for human consumption
- District heating
- Hot wastewater discharge
- Industrial process lines
- Geothermal systems
- Underground conveyance of electrical cables

PE-RT Properties

The long term creep behavior at high temperature has been improved by adjusting the molecular structure to create stronger intermolecular ties.

The improved second generation of PE-RT, "PE-RT Type II", enables production of large pipes and fittings, which gain more and more fields of application where traditional steel pipes can be replaced. PE-RT shares the advantages of PE100 which made it the leading material for plastic pressure pipes:

- Flexibility
- Excellent resistance to impact
- Good weldability that enables making cost effective connections by butt welding or electrofusion

PE-RT Electrofusion Fittings Design And Testing:

The fittings are to be used under specified design pressures and temperatures appropriate to the class of application.

The products are tested and rated for the following pressure classes, according to EN ISO 22391 standard.

Field of Application	Pressure Rating for PLASSON SDR9 Fittings	Application Class, ISO 22391	Temperature/Time at normal temperature	Temperature/Time at maximal temperature	Temperature/Time at peak temperature	Hydrostatic strength tests scheme for PLASSON fittings
Hot Water Supply, 60°C	PN 6	1	60°C/49 years	80°C/1 year	95°C/100 hours	6.4 bar/95°C/ 1100 hours 8.5 bar/80°C/ 1100 hours 19.3 bar/20°C/ 110 hours
Hot Water Supply, 70°C	PN 6	2	70°C/49 years	80°C/1 year	95°C/100 hours	
Underfloor Heating and Low Temperature Radiators	PN 6	4	20°C/2.5 years+ 40°C/20 years+ 60°C/25 years	70°C/2.5 years	100°C/100 hours	
High Temperature Radiators	PN 4	5	20°C/14 years+ 60°C/25 years+ 80°C/10 years	90°C/1 year	100°C/100 hours	

Available products consist of the full range of standard PE100 electrofusion fittings up to diameter 400mm. Above sizes will be provided upon demand.

Tee 90°

490404

Enlace T 90°

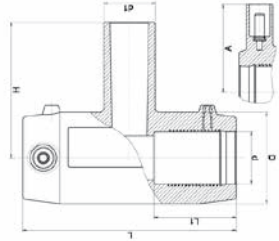

20mm up to 75mm

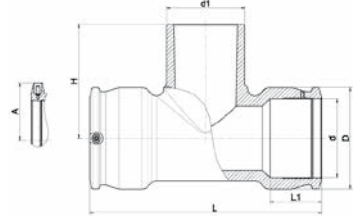

90mm up to 250mm

Product Code	Size dxd1xd	L	L1	D	H	A	UC	W
490404020	20 x 20 x 20	96	37	33	60	39	260	61
490404025	25 x 25 x 25	103	39	44	66	43	168	110
490404032	32 x 32 x 32	104	39	44	74	43	144	97
490404040	40 x 40 x 40	120	43	56	90	47	96	165
490404050	50 x 50 x 50	139	48	68	102	52	56	257
490404063	63 x 63 x 63	167	58	82	119	58	32	417
490404075	75 x 75 x 75	196	63	96	129	62	26	639
490404090	90 x 90 x 90	294	71	113	137	71	15	1090
490404110	110 x 110 x 110	326	71	143	160	81	8	1955
490404125	125 x 125 x 125	382	86	165	177	88	4	2950
490404160	160 x 160 x 160	396	97	209	222	105	3	4758
490404180	180 x 180 x 180	422	106	245	250	116	1	7200
490404200	200 x 200 x 200	451	114	261	265	125	1	8650
490404225	225 x 225 x 225	494	122	293	290	140	1	11860
490404250	250 x 250 x 250	538	129	326	315	152	1	16250

Two Outlets Reducing Tee

492404

Enlace te Reductor con Salida Doble

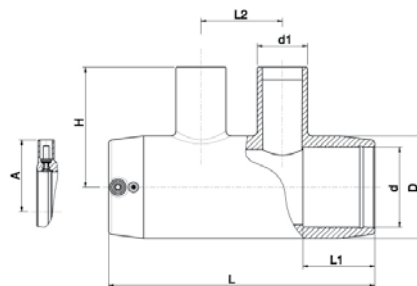

Product Code	Size dxd1 - d1xd	L	L1	L2	D	H	A	UC	W
492404040025	40 x 25 - 25 x 40	176	46	57	56	72	46	96	229
492404040032	40 x 25 - 25 x 40	176	46	57	56	76	46	75	233
492404050025	50 x 25 - 25 x 50	195	49	65	68	79	51	56	342
492404050032	50 x 32 - 32 x 50	195	49	65	68	83	51	58	336
492404050040	50 x 32 - 32 x 50	195	49	65	68	89	51	52	352
492404063025	63 x 32 - 32 x 63	213	58	65	82	86	57	42	457
492404063032	63 x 40 - 40 x 63	213	58	65	82	90	57	40	464
492404063040	63 x 40 - 40 x 63	213	58	65	82	96	57	36	480

Reducing Tee

491404

Enlace T Reductor

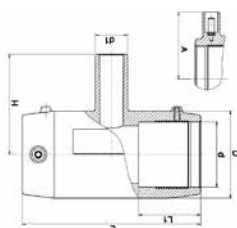

20mm up to 75mm

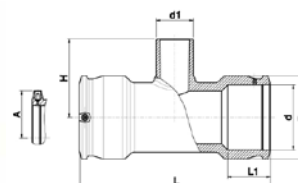

90mm up to 250mm

Product Code	Size dxd1xd	L	L1	D	H	A	UC	W
491404025020	25 x 20 x 25	104	39	44	66	43	168	108
491404025032	25 x 32 x 25*	104	39	44	74	43	168	116
491404032020	32 x 20 x 32	104	39	44	66	43	144	89
491404032025	32 x 25 x 32	104	39	44	66	43	144	91
491404040020	40 x 20 x 40	120	43	56	72	47	96	151
491404040025	40 x 25 x 40	120	43	56	72	47	96	150
491404040032	40 x 32 x 40	120	43	56	75	47	96	152
491404050020	50 x 20 x 50	139	48	68	78	52	64	224
491404050025	50 x 25 x 50	139	48	68	78	52	64	225
491404050032	50 x 32 x 50	139	48	68	86	52	64	228
491404050040	50 x 40 x 50	139	48	68	90	52	64	237
491404063020	63 x 20 x 63	167	49	82	85	58	40	348
491404063032	63 x 32 x 63	167	58	82	93	58	32	353
491404063040	63 x 40 x 63	167	58	82	104	58	32	365
491404063050	63 x 50 x 63	167	58	82	109	58	32	381
491404075063	75 x 63 x 75	196	63	96	122	62	26	607
491404090063	90 x 63 x 90	294	68	113	124	71	15	1050
491404090075	90 x 75 x 90	293	71	36	14	71	112	137
491404110063	110 x 63 x 110	326	71	143	134	81	9	1715
491404110075	110 x 75 x 110	328	72	143	142	81	9	1730
491404110090	110 x 90 x 110	326	71	143	147	81	8	1815
491404125090	125 x 90 x 125	382	86	165	161	88	5	2805
491404125110	125 x 110 x 125	382	86	165	173	88	5	2859
491404160090	160 x 90 x 160	396	97	209	192	105	3	4185
491404160110	160 x 110 x 160	440	86	208	193	106	3	4470
491404160125	160 x 125 x 160	440	86	208	198	106	3	4470
491404180090	180 x 90 x 180	422	106	245	200	116	2	6090
491404180110	180 x 110 x 180	422	106	245	219	116	2	6270
491404180125	180 x 125 x 180	422	106	245	225	116	2	6410
491404180140	180 x 140 x 180	422	106	245	237	116	1	6610
491404180160	180 x 160 x 180	422	106	245	250	116	1	6950
491404200090	200 x 90 x 200	451	114	261	205	125	2	7140
491404200110	200 x 110 x 200	451	114	261	210	125	2	7235
491404225090	225 x 90 x 225	494	122	293	220	140	1	9900
491404225110	225 x 110 x 225	494	122	293	225	140	1	10000
491404250090	250 x 90 x 250	538	129	326	235	152	1	13350
491404250110	250 x 110 x 250	538	129	326	240	152	1	13400

* This size enlarges | * Esta media agranda

Flanged Tee

499404

Enlace T Bridado

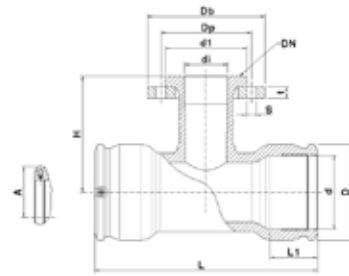

Product Code	Size d x DN x d	L	L1	D	H	A	t	s	d1	DP	UC	W
499404090080	90 x 80 x 90	294	71	113	165	71	20	8 x 18	138	160	8	2835
499404110080	110 x 80 x 110	326	71	143	181	81	20	8 x 18	138	160	6	3560
499404110100	110 x 100 x 110	326	71	143	181	81	22	8 x 18	158	180	6	4240
499404125080	125 x 80 x 125	382	86	165	190	88	20	8 x 18	138	160	4	4550
499404125100	125 x 100 x 125	382	86	165	190	88	22	8 x 18	158	180	3	5180
499404160080	160 x 80 x 160	440	86	208	210	106	20	8 x 18	138	160	3	6245
499404160100	160 x 100 x 160	440	86	208	210	106	22	8 x 18	158	180	3	6785
499404180080	180 x 80 x 180	422	106	245	225	116	20	8 x 18	138	160	2	7745
499404180100	180 x 100 x 180	422	106	245	225	116	22	8 x 18	158	180	1	8550
499404200080	200 x 80 x 200	451	114	261	240	125	20	8 x 18	138	160	1	8530
499404200100	200 x 100 x 200	451	114	261	245	125	22	8 x 18	158	180	1	9230
499404225080	225 x 80 x 225	494	122	293	255	140	20	8 x 18	138	160	1	11240
499404225100	225 x 100 x 225	494	122	293	260	140	22	8 x 18	158	180	1	11900
499404250080	250 x 80 x 250	538	129	326	270	152	20	8 x 18	138	160	1	14750
499404250100	250 x 100 x 250	538	129	326	275	152	22	8 x 18	158	180	1	15400

Elbow 90°

490504

Codo 90°

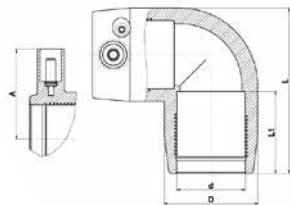

20mm up to 75mm

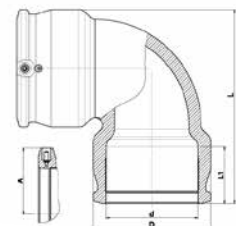

90mm up to 250mm

Product Code	Size d	L	L1	D	A	UC	W
490504020	20	66	35	36	38	320	65
490504025	25	66	37	36	38	320	52
490504032	32	83	40	44	43	192	85
490504040	40	92	44	55	47	120	138
490504050	50	108	48	68	52	72	211
490504063	63	131	57	81	59	40	320
490504075	75	158	69	97	62	33	527
490504090	90	213	78	113	69	19	875
490504110	110	243	79	143	79	9	1519
490504125	125	271	100	165	89	7	2424
490504140	140	309	93	183	94	4	3024
490504160	160	323	87	209	106	3	3990
490504180	180	412	105	244	115	2	7590
490504200	200	449	112	262	124	1	8670
490504225	225	498	121	295	140	1	12200
490504250	250	550	130	327	152	1	13500

Elbow 45°

490604

Codo 45°

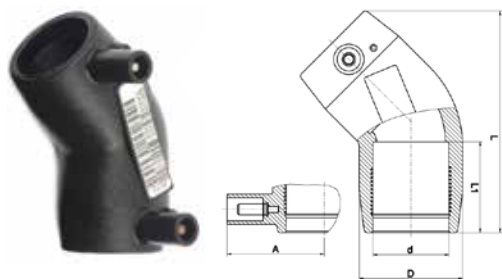

32mm up to 75mm

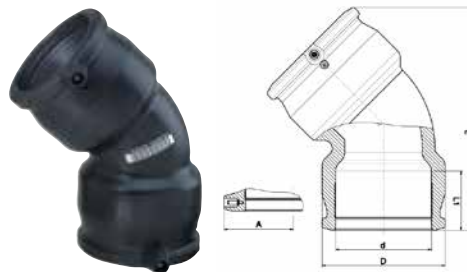

90mm up to 250mm

Product Code	Size d	L	L1	D	A	UC	W
490604032	32	95	39	45	43	240	75
490604040	40	108	42	55	46	160	117
490604050	50	125	49	68	51	96	181
490604063	63	148	57	81	59	60	264
490604075	75	180	71	96	62	40	426
490604090	90	243	75	112	69	22	759
490604110	110	271	81	143	78	12	1269
490604125	125	304	86	165	88	8	2030
490604140	140	342	92	182	95	5	2471
490604160	160	350	95	209	105	4	3350
490604180	180	434	105	244	114	2	6150
490604200	200	472	112	261	125	1	7050
490604225	225	520	120	294	140	1	9800
490604250	250	571	129	326	151	1	13400

Elbow 22.5°

490804

Codo 22.5°

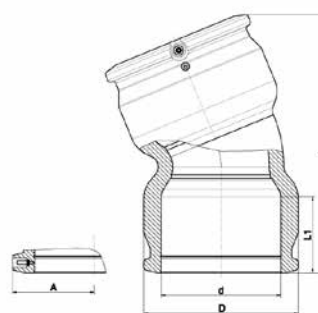

Product Code	Size d	L	L1	D	A	UC	W
490804090	90	214	72	113	71	26	665
490804110	110	232	71	143	81	14	1087
490804125	125	274	86	165	88	8	1850
490804160	160	302	86	209	106	5	2930
490804180	180	391	105	244	115	2	5360

LightFit Elbow 45°

46060

Codo LightFit 45°

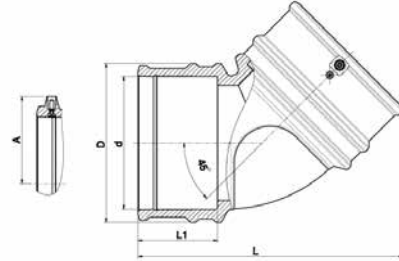

Product Code	Size d	L	L1	D	A	UC	W
460604160	160	323	98	193	106	4	1976

LightFit Elbow 30°

46330

Codo LightFit 30°

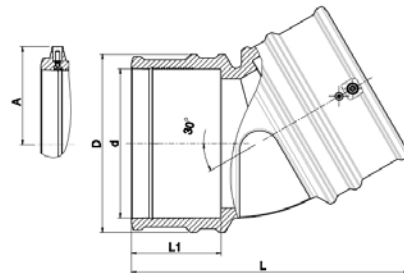

Product Code	Size d	L	L1	D	A	UC	W
463304160	160	300	98	193	106	4	1798

LightFit Elbow 15°

46370

Codo LightFit 15°

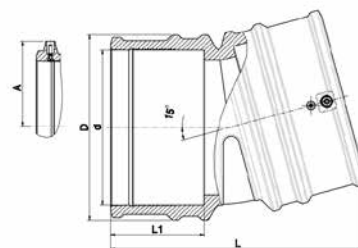

Product Code	Size d	L	L1	D	A	UC	W
463704160	160	265	98	193	106	6	1728

Elbow 180°

490904

Codo 180°

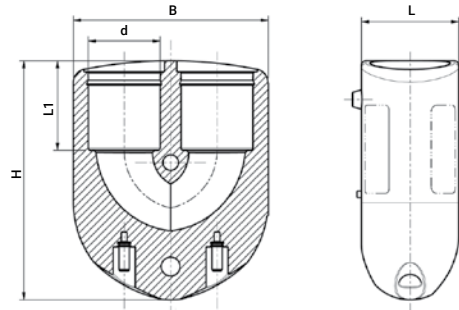

Product Code	Size d	L	L1	H	B	UC	W
490904025	25	38	38	99	72	216	169
490904032	32	44	41	108	88	144	216
490904040	40	53	48	123	106	80	323

Y Reducer

491904

Y Reductor

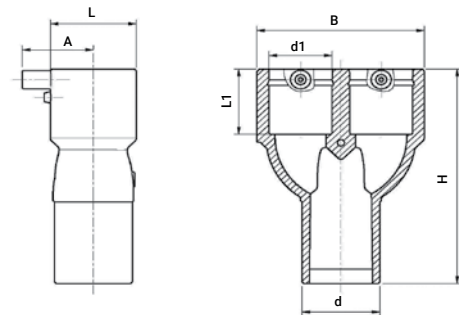

Product Code	Size d x d1 x d1	L	L1	B	A	H	UC	W
491904032025	32 x 25 x 25	36	40	70	38	119	200	97
491904040032	40 x 32 x 32	45	43	87	42	133	120	151
491904050040	50 x 40 x 40	56	46	108	46	151	80	242

Duckfoot Elbow 90°

491504

Codo 90° Empotrable

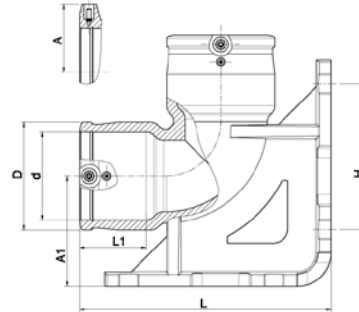

Product Code	Size d	L	L1	D	A	A1	H	UC	W
491504090	90	261	69	112	71	115	146	5	2260

Duckfoot Elbow 90° With Outlet

4915Q4

Codo 90° Emportable con toma de servicio

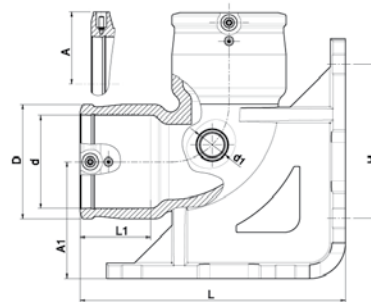

Product Code	Size d x d1	L	L1	D	A	A1	H	UC	W
4915Q4090032	90 x 32	261	69	112	71	115	146	5	2265

Adjustable Elbow

4947C4

Codo Ajustable

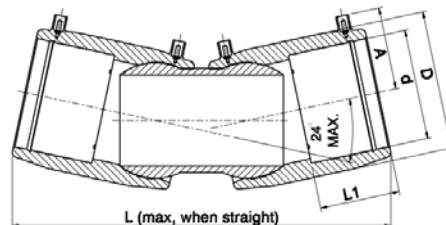

Product Code	Size d	L	L1	D	A	UC	W
4947C4090	90	341	72	116	77	12	1450
4947C4110	110	362	80	140	83	8	2030
4947C4125	125	382	85	157	95	8	2630
4947C4160	160	453	97	215	106	3	4510
4947C4180	180	511	104	224	128	2	7490
4947C4200	200	512	104	250	125	2	9733
4947C4225	225	600	105	282	141	1	13230
4947C4250	250	644	123	312	156	1	16775

Adjustable Elbow One Sided

4947D4

Codo Ajustable Enlace/Espiga

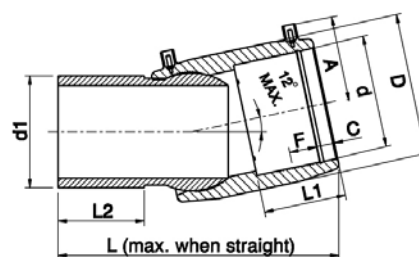

Product Code	Size d x d1	L	L1	L2	D	A	UC	W
4947D4090	90 x 90	258	72	82	116	77	20	940
4947D4110	110 x 110	276	85	85	140	83	12	1290
4947D4125	125 x 125	292	90	90	157	95	12	1740
4947D4160	160 x 160	341	97	100	215	106	4	3150
4947D4180	180 x 180	365	138	138	223	128	3	4210
4947D4200	200 x 200	370	104	116	250	125	2	6172
4947D4225	225 x 225	426	105	124	282	141	2	8340
4947D4250	250 x 250	455	123	134	312	156	1	10800

Balloon Saddle

496804

Collarín Globo

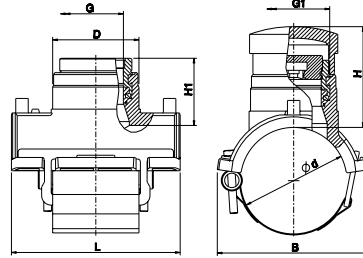

Product Code	Size d x G	G1	B	H	H1	D	L	UC	W
496804090025	90 x 2"	2 1/2"	142	105	70	90	176	10	1961
496804110025	110 x 2"	2 1/2"	160	105	70	90	176	10	1973
496804125025	125 x 2"	2 1/2"	169	105	70	90	176	10	1981
496804140025	140 x 2"	2 1/2"	174	105	70	90	176	10	2000
496804160025	160 x 2"	2 1/2"	176	105	70	90	176	10	1984
496804180025	180 x 2"	2 1/2"	182	105	70	90	176	10	1997
496804200025	200 x 2"	2 1/2"	202	105	70	90	176	10	1991
496804225025	225 x 2"	2 1/2"	227	105	70	90	176	10	2003
496804250025	250 x 2"	2 1/2"	252	105	70	90	176	10	2010

Monolithic Weld End Cap for Balloon Saddle

498304

Tapón Monolítico Soldable para collarín globo

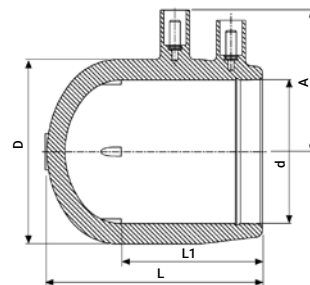

Product Code	Size d	L	L1	D	A	UC	W
498304090	90	123	77	117	77	55	479

Saddle Female Rp Threaded Outlet

4958T4

Collarín BSPP Rosca Hembra

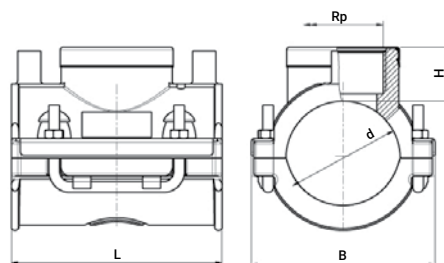

Product Code	Size d x Rp	B	H	L	UC	W
4958T4063007	63 x 3/4"	100	30	118	60	385
4958T4063010	63 x 1"	100	30	118	60	390
4958T4063013	63 x 1 1/4"	100	30	118	60	400
4958T4063015	63 x 1 1/2"	100	30	118	60	400
4958T4090010	90 x 1"	126	30	118	36	520
4958T4090013	90 x 1 1/4"	126	30	118	36	530
4958T4090015	90 x 1 1/2"	126	30	118	36	540

Repair Saddle

495204

Toma de Reparación

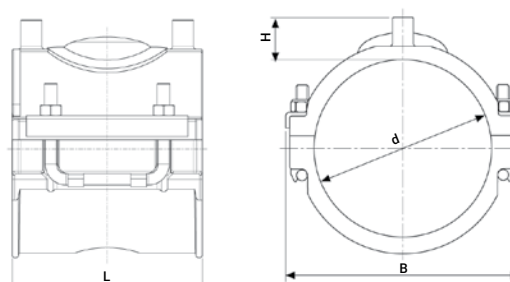

Product Code	Size d	B	H	L	Max Damage Length	UC	W
495204063	63	100	29	118	38	72	378
495204075	75	117	29	118	38	48	410
495204090	90	126	29	118	38	40	504
495204110	110	148	29	118	38	32	555
495204125	125	162	29	118	38	24	620
495204140	140	180	29	118	38	24	660
495204160	160	199	29	118	38	24	718
495204180	180	219	29	118	38	16	759

Transition Saddle

493804

Collarín de Transición



63mm up to 180mm
Outlets 1 1/4" and 1 1/2"



90mm up to 250mm
Outlet 2"

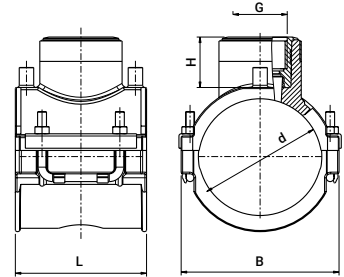

Product Code	Size d x G	B	H	L	UC	W
493804063013	63 x 1 1/4"	100	53	118	48	612
493804075013	75 x 1 1/4"	117	53	118	40	656
493804090015	90 x 1 1/2"	121	53	118	16	930
493804090020	90 x 2"	142	76	176	14	1436
493804110015	110 x 1 1/2"	142	53	118	12	1006
493804110020	110 x 2"	158	76	176	12	1500
493804125015	125 x 1 1/2"	158	53	118	12	1049
493804125020	125 x 2"	166	76	176	12	1510
493804140015	140 x 1 1/2"	175	53	118	10	1072
493804140020	140 x 2"	174	76	176	10	1520
493804160015	160 x 1 1/2"	196	53	118	8	1163
493804160020	160 x 2"	176	76	176	10	1540
493804180015	180 x 1 1/2"	216	53	118	6	1200
493804180020	180 x 2"	182	76	176	10	1500
493804200020	200 x 2"	202	76	176	10	1575
493804225020	225 x 2"	227	76	176	10	1570
493804250020	250 x 2"	252	76	176	10	1546

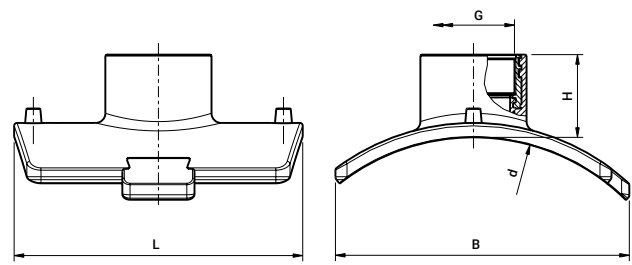

Product Code	Size d x G	B	H	L	UC	W
493804400020*	250-400 x 2"	305	77	306	8	1975
493804710020*	450-800 x 2"	315	77	306	8	1960

* See dedicated tools on page 188 | * Ver herramientas necesarias en pag. 188

PLASSON Electrofusion Saddles

For Large Diameter PE Pipes



495804 | 5958B



4758W



495904



495803



495204



493804

PLASSON

ALTERNATIVE



TRANSPORTING

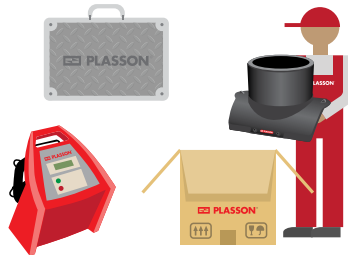
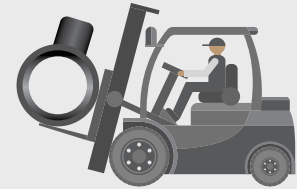

APPLICATION

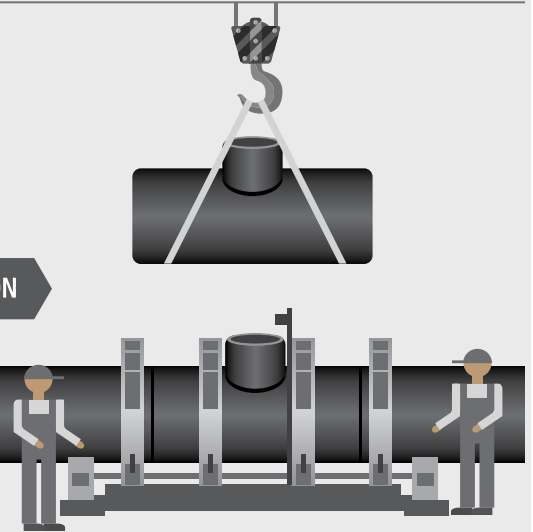

STORAGE

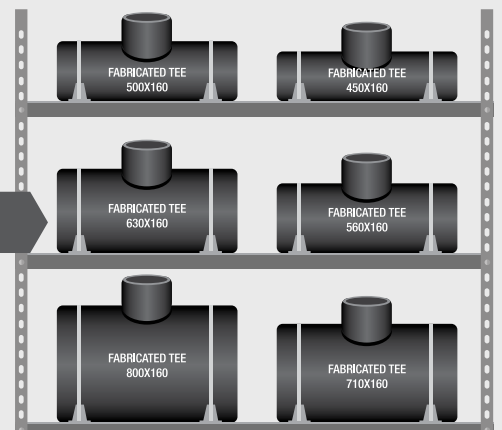

PE has become well established in pipeline applications since its introduction in the 1950s.

The numerous benefits of PE material include its flexibility, corrosion resistance and the option of fully welded systems, all leading to PE systems being used in a wide field of applications and increasingly larger diameters. Plasson, in keeping with latest market trends, continues to develop innovative fittings and installation tools, providing the end users all that is required in order to perform their task in the most convenient and professional way.

Plasson electrofusion fittings are designed for optimal performance using FEA (Final Element Analysis) software. The combination of engineering experience gained over 25 years, and use of leading PE 100 materials in the market provide for an estimated service life of over 100 years.



PLASSON Sensor Adaptor

Plasson Sensor Adaptor provides a dedicated solution for connecting the sensor to the piping system, eliminating the need to apply leak-prone improvised connections. Plasson's Sensor adaptors enable quick and easy integration of various sensors onto a wide range of PE pipe diameters. Pressure rated Water PN16, Gas PE100 SDR11. Threaded brass/Stainless Steel Outlets according to ISO 7-1 (Female Rp thread), available in dimensions 1/2", 3/4" and 1".



Universal

- Two Saddles cover extensive range of pipe diameters:
- 110 (4" IPS) – 400mm (16" IPS)
- 450 (18" IPS) – 1200mm (48" IPS)

Fast and simple installation

The Sensor Adaptor is designed to deal with the challenges of connecting to large PE pipes, such as ovality and deformation resulting from aging, handling and storage by obtaining full contact along the welding zone.

Using one of the two unique yet simple clamping device options (Strap or Bolt) ensures the correct welding of the Sensor Adaptor.

- Correct tightening force indicator on strap mechanism

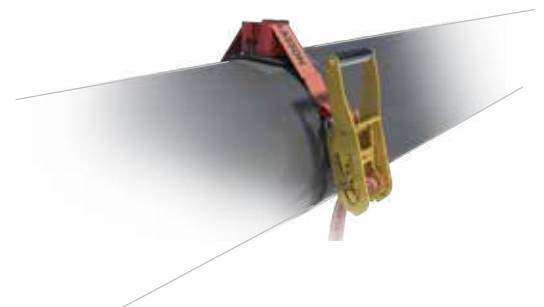

Specifications

The fittings are tested and approved to meet the following standard requirements:

- ISO 4427, Part 3 (Water), ISO 4437, Part 3 (Gas)
- EN 12201, Part 3 (Water), EN 1555, Part 3 (Gas)
- AS/NZS 4129: 2008
- DVGW GW 335-B2

Sensor Adaptor with Brass Thread

493803*

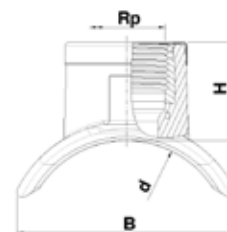
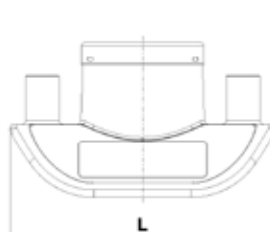

Product Code	Size d x Rp**	B	H	L	UC	W
493803400005	110-400 x 1/2"	85	35	103	140	120
493803400007	110-400 x 3/4"	85	38	103	140	120
493803400010	110-400 x 1"	85	38	103	140	120
493803900005	450-1200 x 1/2"	85	35	103	140	120
493803900007	450-1200 x 3/4"	85	38	103	140	120
493803900010	450-1200 x 1"	85	38	103	140	120

* See dedicated tools on page 183 | * Ver herramientas necesarias en pag. 183

Sensor Adaptor with a Stainless Steel thread

4938S3*

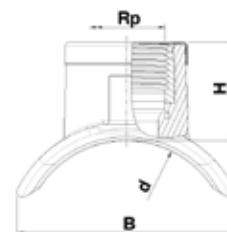
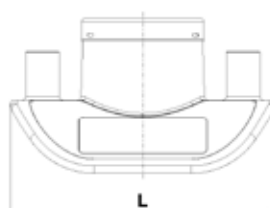

Product Code	Size d x Rp	H	B	L	UC	W
4938S3400005	110-400 x 1/2"	35	85	103	140	109.3
4938S3400007	110-400 x 3/4"	38	85	103	140	120
4938S3400010	110-400 x 1"	38	85	103	140	148.3
4938S3900005	450-1200 x 1/2"	35	85	103	140	109.3
4938S3900007	450-1200 x 3/4"	38	85	103	140	120
4938S3900010	450-1200 x 1"	38	85	103	140	148.3

* See dedicated tools on page 183 | * Ver herramientas necesarias en pag. 183

** NPT thread available upon request

Branch Saddle

495804

Collarín de Derivación



63mm up to 180mm
Outlets 32mm to 63mm



200mm up to 315mm
and all sizes with Outlet 90mm

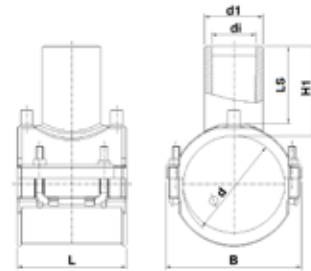

Product Code	Size d x d1	B	H1	LS	L	di	UC	W
495804063032	63 x 32	100	59	49	118	23	56	394
495804063040	63 x 40	100	78	66	118	29.5	40	400
495804063050	63 x 50	100	93	82	118	37.5	40	430
495804063063	63 x 63	100	94	85	118	45	40	462
495804075032	75 x 32	117	59	49	118	23	48	431
495804075040	75 x 40	117	78	66	118	29.5	36	451
495804075050	75 x 50	117	93	82	118	37.5	32	465
495804075063	75 x 63	117	94	85	118	45	32	522
495804090032	90 x 32	126	59	49	118	23	32	519
495804090040	90 x 40	126	78	68	118	29.5	32	529
495804090050	90 x 50	126	93	82	118	37.5	32	550
495804090063	90 x 63	126	94	85	118	45	24	608
495804090090	90 x 90	139	105	90	176	66	15	934
495804110032	110 x 32	148	59	49	118	23	24	585
495804110040	110 x 40	148	78	68	118	29.5	24	598
495804110050	110 x 50	148	93	82	118	37.5	20	629
495804110063	110 x 63	148	94	85	118	45	20	658
495804110090	110 x 90	162	105	90	176	68	18	949
495804125032	125 x 32	162	59	49	118	23	24	634
495804125040	125 x 40	162	78	68	118	29.5	20	644
495804125050	125 x 50	162	93	82	118	37.5	20	670
495804125063	125 x 63	162	94	85	118	45	16	703
495804125090	125 x 90	169	105	90	176	68	18	953
495804140032	140 x 32	180	59	49	118	23	24	661
495804140040	140 x 40	180	78	68	118	29.5	16	677
495804140050	140 x 50	180	93	82	118	37.5	16	705
495804140063	140 x 63	180	94	85	118	45	16	740
495804140090	140 x 90	174	105	90	176	68	16	965
495804160032	160 x 32	200	59	49	118	23	16	744
495804160040	160 x 40	200	78	68	118	29.5	16	757
495804160050	160 x 50	200	93	82	118	37.5	16	778
495804160063	160 x 63	200	94	85	118	45	16	804
495804160090	160 x 90	176	105	90	176	68	16	961
495804180032	180 x 32	219	59	49	118	23	16	800
495804180040	180 x 40	219	78	68	118	29.5	12	800
495804180050	180 x 50	219	93	82	118	37.5	12	828
495804180063	180 x 63	219	94	85	118	45	12	886
495804180090	180 x 90	182	105	90	176	68	15	962
495804200063	200 x 63	202	102	85	176	47	15	862
495804200090	200 x 90	202	105	90	176	68	15	900
495804225063	225 x 63	227	102	85	176	47	15	882
495804225090	225 x 90	227	105	90	176	68	15	983
495804250063	250 x 63	252	102	85	176	47	15	970
495804250090	250 x 90	252	105	90	176	68	15	1070

Branch Saddle*

495804

Collarín de Derivación*

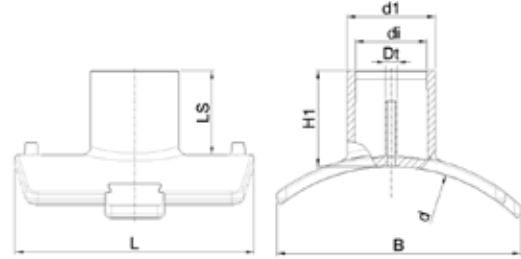

Product Code	Size d x d1	B	H1	LS	L	di	Dt	UC	W
495804400090T	280 - 400 x 90	305	115	102	300	73	16	7	1510
495804400110T	280 - 400 x 110	305	117	104	300	89	16	7	1650
495804400125T	280 - 400 x 125	305	110	119	300	101	16	6	1760
495804400160T	280 - 400 x 160	305	132	119	300	130	16	6	2167
495804710090T	450 - 800 x 90	315	117	105	300	73	16	7	1598
495804710110T	450 - 800 x 110	315	117	105	300	89	16	7	1601
495804710125T	450 - 800 x 125	315	117	109	300	101	16	7	1739
495804710160T	450 - 800 x 160	315	130	115	300	130	16	6	2017

* See "Large bore saddles installation tools" section at page 184 | * Consulte la sección "Herramientas de instalación de Tomas Simples/ Acometidas/Ramales de gran diámetro" en la página 184.

Branch Saddle

4958X4

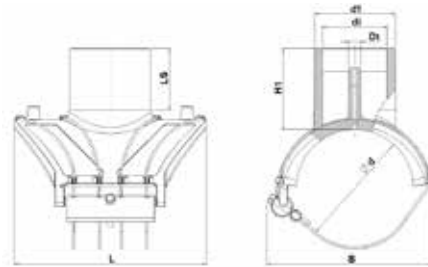

Product Code	Size d x d1	B	H1	LS	L	di	Dt	UC	W
4958X4125090T	125 x 90	180	106	81	242	73	16	9	890
4958X4125110T	125 x 110	180	109	84	242	89	16	9	1000
4958X4140090T	140 x 90	189	106	81	242	73	16	9	830
4958X4140110T	140 x 110	189	109	84	242	89	16	9	900
4958X4160090T	160 x 90	222	107	81	263	73	16	6	1330
4958X4160110T	160 x 110	222	110	84	263	89	16	6	1220
4958X4180090T	180 x 90	229	107	81	263	73	16	6	1480
4958X4180110T	180 x 110	229	110	84	263	89	16	6	1140
4958X4200090T	200 x 90	277	109	81	295	73	16	6	1960
4958X4200110T	200 x 110	277	111	84	295	89	16	6	1930
4958X4225090T	225 x 90	277	109	81	295	73	16	6	1800
4958X4225110T	225 x 110	277	112	85	295	89	16	6	1500
4958X4225160T	225 x 160	291	167	152	338	131	16	—	—
4958X4250090T	250 x 90	280	109	81	295	73	16	6	1650
4958X4250110T	250 x 110	280	111	84	295	89	16	6	1310
4958X4250160T	250 x 160	291	167	152	338	160	16	—	—

PLASSON New Branch Saddle



PLASSON has developed a new range of innovative designed branch saddles equipped with an integrated clamping mechanism for a quick, easy and accessory free installation process.

The new branch saddles exceed the performance requirements of the toughest national and international standards in the market.

Our new saddles offer an innovative design, simplifying the installation process by eliminating the need for dedicated clamping tools.

Single bolt

- No clamping tools.
- By tightening the bolt, the cables clamp the saddle to the pipe, ensuring a uniform high quality weld.

Full bore

- Minimal head loss.
- SDR 11 outlet suitable for electrofusion or butt weld connections.

Weld integrity test

- Special test port is incorporated into the saddle, enabling pressure testing of the weld prior to cutting into the pipe mains.

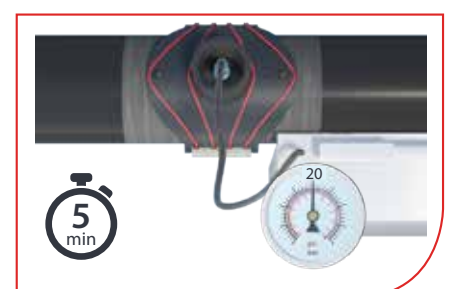

Milder

— VEELZJDIG IN LEIDINGSYSTEMEN —

Milder Bemmel
Tel. 026 - 325 91 03

Milder Rotterdam
Tel. 010 - 415 99 83

info@milder.nl
www.milder.nl

XL&XXL Branch Saddle*

495803

XL&XXL Collarín de Derivación*

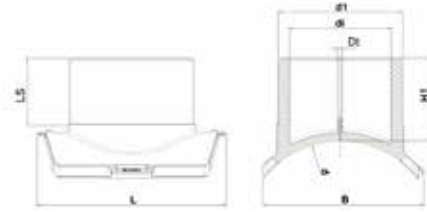

Product Code	d x d1	B	L	d _i	LS	H1	Dt	UC	W
495803355250T	315-355 x 250	390	420	204	140	200	16	1	7420
495803400180T	400 x 180	393	470	147	135	169	16	1	4800
495803400200T	400 x 200	377	470	163	142	180	16	1	5950
495803400225T	400 x 225	380	470	184	150	189	16	1	6560
495803400250T	400 x 250	400	470	204	160	215	16	1	7900
495803450180T	450 x 180	393	470	147	135	169	16	1	5000
495803450200TN	400-450 x 200	373	420	164	142	182	16	1	5300
495803450225TN	400-450 x 225	373	420	184	142	182	16	1	6050
495803450250T	450 x 250	405	470	204	160	195	16	1	7900
495803450280T	450 x 280	450	530	230	169	225	16	1	10900
495803450315T	450 x 315	450	530	257	180	220	16	1	13000
495803500180T	500 x 180	411	470	147	135	169	16	1	—
495803500200T	500 x 200	398	470	163	142	180	16	1	5870
495803500225T	500 x 225	400	470	184	150	189	16	1	6200
495803500280T	500 x 280	465	530	230	169	225	16	1	10800
495803500315T	500 x 315	480	540	257	180	227	16	1	13500
495803500355T	500 x 355	500	610	252	194	252	16	1	17670
495803560180T	560 x 180	416	470	147	135	169	16	1	—
495803560200T	560 x 200	400	470	163	142	180	16	1	5600
495803560225T	560 x 225	400	470	184	150	189	16	1	6500
495803560280T	560 x 280	477	530	230	169	225	16	1	—
495803560315T	560 x 315	472	540	257	180	227	16	1	12800
495803560355T	560 x 355	512	610	252	194	252	16	1	17200
495803560400T	560 x 400	505	620	327	209	258	16	1	20100
495803630180T	630 x 180	420	470	147	135	169	16	1	—
495803630200TN	500 - 630 x 200	425	420	164	160	185	16	1	5300
495803630225TN	500 - 630 x 225	425	420	184	203	225	16	1	5900
495803630250T	500 - 630 x 250	400	420	205	203	225	16	1	6670
495803630280T	630 x 280	489	530	230	169	225	16	1	10900
495803630315T	630 x 315	481	540	257	180	227	16	1	12700
495803630355T	630 x 355	522	610	252	194	252	16	1	—
495803630400T	630 x 400	520	620	327	209	258	16	1	20400
495803710180T	710 x 180	425	470	147	135	169	16	1	—
495803710200T	710 x 200	410	470	163	142	180	16	1	5780
495803710225T	710 x 225	410	470	184	150	187	16	1	6400
495803710250T	710 x 250	430	470	204	160	195	16	1	7500
495803710280T	710 x 280	498	530	230	169	225	16	1	10900
495803710315T	710 x 315	500	530	257	180	220	16	1	12600
495803710355T	710 x 355	532	610	252	194	252	16	1	—
495803710400T	710 x 400	530	610	327	209	250	16	1	19400
495803800180T	800 x 180	430	470	147	135	169	16	1	4700
495803800200T	800 x 200	410	470	163	142	180	16	1	5790
495803800225T	800 x 225	415	470	184	150	189	16	1	6200
495803800250T	800 x 250	430	470	204	160	197	16	1	7500
495803800280T	800 x 280	505	530	230	169	225	16	1	—
495803800315T	800 x 315	510	530	257	180	220	16	1	12200
495803800355T	800 x 355	543	610	252	194	252	16	1	—
495803800400T	800 x 400	540	610	327	209	250	16	1	20000

* See "Large bore saddles installation tools" section at page 184 | * Consulte la sección "Herramientas de instalación de Tomas Simples/ Acometidas/Ramales de gran diámetro" en la página 184.

XL&XXL Branch Saddle**

495803

XL&XXL Collarín de Derivación**

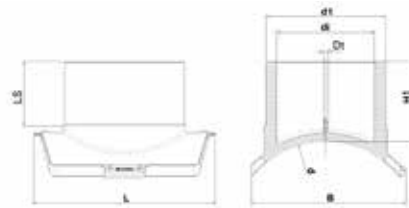

Product Code	d x d1	B	L	di	LS	H1	Dt	UC	W
495803900110T	900 x 110	320	300	89	105	123	16	6	1900
495803900125T	900 x 125	320	300	101	110	130	16	6	2100
495803900160T	900 x 160	295	300	130	113	131	16	6	2390
495803900180T	900 x 180	435	470	147	135	169	16	1	4600
495803900200T	900 x 200	415	470	163	142	180	16	1	5300
495803900225T	900 x 225	415	470	184	150	189	16	1	—
495803900250T	900 x 250	440	470	204	160	197	16	1	7200
495803900280T	900 x 280	511	530	230	169	225	16	1	10900
495803900315T	900 x 315	510	530	257	180	220	16	1	12100
495803900355T	900 x 355	554	610	252	194	252	16	1	—
495803900400T	900 x 400	550	610	327	209	250	16	1	20000
4958031000110T	1000 x 110	320	300	89	105	123	16	6	2000
4958031000125T	1000 x 125	320	300	101	110	128	16	6	2200
4958031000160T	1000 x 160	320	300	130	120	138	16	6	3000
4958031000180T	1000 x 180	443	470	147	166	184	16	1	4600
4958031000200T	1000 x 200	443	470	163	176	198	16	1	5800
4958031000225T	1000 x 225	443	470	184	181	203	16	1	6200
4958031000250T	1000 x 250	443	470	204	190	213	16	1	7360
4958031000280T	1000 x 280	516	530	230	169	225	16	1	—
4958031000315T	1000 x 315	516	530	257	211	236	16	1	12,320
4958031000355T	1000 x 355	563	610	252	194	252	16	1	16,830
4958031000400T	1000 x 400	563	610	327	240	267	16	1	20,000
4958031200110T	1200 x 110	320	300	89	105	123	16	6	2000
4958031200125T	1200 x 125	320	300	101	110	128	16	6	2200
4958031200160T	1200 x 160	320	300	130	120	138	16	6	2500
4958031200180T	1200 x 180	447	470	147	166	184	16	1	4700
4958031200200T	1200 x 200	447	470	163	176	198	16	1	5740
4958031200225T	1200 x 225	447	470	184	181	203	16	1	6350
4958031200250T	1200 x 250	447	470	204	190	213	16	1	7370
4958031200280T	1200 x 280	527	530	230	169	225	16	1	—
4958031200315T	1200 x 315	526	530	257	211	236	16	1	12000
4958031200355T	1200 x 355	575	610	252	194	252	16	1	—
4958031200400T	1200 x 400	574	610	327	240	267	16	1	20,000

* See "Large bore saddles installation tools" section at page 184 | * Consulte la sección "Herramientas de instalación de Tomas Simples/ Acometidas/Ramales de gran diámetro" en la página 184.

LightFit Branch Saddle

4758W

Collarín de Derivación LightFit

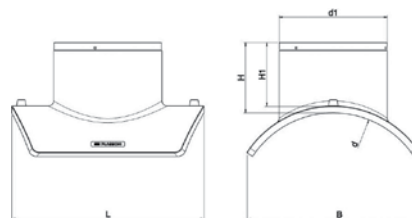

Product Code	d x d1	B	L	H	H1	UC	W
4758W4450225	315 - 450 x 225	359	400	145	130	1	3700
4758W4630225	450 - 630 x 225	389	400	145	130	1	3740
4758W4800225	630 - 800 x 225	407	400	145	130	1	3835

* See "Large bore saddles installation tools" section at page 184 | * Consulte la sección "Herramientas de instalación de Tomas Simples/ Acometidas/Ramales de gran diámetro" en la página 184.

Flange Branch Saddle*

495904

Collarín bridado

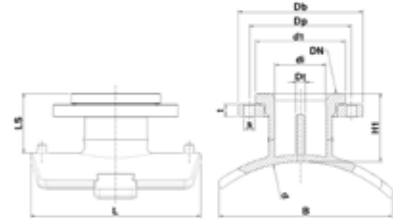

Product Code	Flange Type	d x DN	B	L	di	dh	Db	Dt	Dp	LS	H1	s	t	UC	W
495904400080T	ISO/DIN PN 10/16	280 - 400 x 80	305	300	73	138	200	16	160	102	115	18	20	1	2930
495904400100T	ISO/DIN PN 10/16	280 - 400 x 100	309	300	102	158	220	16	180	110	121	18	22	1	3530
495904400150T	ISO/DIN PN 10/16	280 - 400 x 150	305	300	131	212	285	16	240	119	132	22	24	1	6330
495903400250T	ISO/DIN PN 16	400 x 250	400	420	204	320	410	16	355	250	206	26	33	1	16300
495903450200TN	ISO/DIN PN 16	400-450 x 200	373	420	184	268	344	16	295	250	275	22	28	1	11730
495903450250T	ISO/DIN PN 16	450 x 250	405	470	204	320	410	16	355	250	275	26	33	1	—
495903450300T	ISO/DIN PN 16	450 x 300	450	530	257	370	467	16	410	250	275	26	40	1	27300
495903500300T	ISO/DIN PN 16	500 x 300	460	530	257	370	467	16	410	250	275	26	40	1	22700
495903560300T	ISO/DIN PN 16	560 x 300	475	530	257	370	467	16	410	250	275	26	40	1	22750
495903560400T	ISO/DIN PN 16	560 x 400	510	610	327	482	595	16	525	250	280	30	54	1	—
495903630200TN	ISO/DIN PN 16	500 - 630 x 200	405	420	184	268	344	16	295	250	275	22	28	1	11900
495903630250T	ISO/DIN PN 16	500 - 630 x 250	425	420	204	320	410	16	355	250	206	26	33	1	15400
495903630300T	ISO/DIN PN 16	630 x 300	490	530	257	370	467	16	410	250	275	26	40	1	27300
495903630400T	ISO/DIN PN 16	630 x 400	520	610	327	482	595	16	525	250	280	30	54	1	—
495903710200T	ISO/DIN PN 16	710 x 200	410	470	184	268	344	16	295	250	275	22	28	1	—
495903710250T	ISO/DIN PN 16	710 x 250	430	470	204	320	410	16	355	250	275	26	33	1	—
495903710300T	ISO/DIN PN 16	710 x 300	500	530	257	370	467	16	410	250	275	26	40	1	—
495903710400T	ISO/DIN PN 16	710 x 400	530	610	327	482	595	16	525	250	280	30	54	1	—
495904710080T	ISO/DIN PN 10/16	450 - 800 x 80	315	300	73	138	200	16	160	105	117	18	20	1	2960
495904710100T	ISO/DIN PN 10/16	450 - 800 x 100	315	300	102	158	220	16	180	110	123	22	22	1	3530
495904710150T	ISO/DIN PN 10/16	450 - 800 x 150	315	300	131	212	285	16	240	121	132	22	24	1	6300
495903800200T	ISO/DIN PN 16	800 x 200	410	470	184	268	344	16	295	250	275	22	28	1	12270
495903800250T	ISO/DIN PN 16	800 x 250	430	470	204	320	410	16	355	250	275	26	33	1	—
495903800300T	ISO/DIN PN 16	800 x 300	510	530	257	370	467	16	410	250	275	26	40	1	27600
495903800400T	ISO/DIN PN 16	800 x 400	540	610	327	482	595	16	525	250	280	30	54	1	45800
495903900150T	ISO/DIN PN 10/16	900 x 150	318	300	131	212	285	16	240	120	132	18	24	1	6640
495903900200T	ISO/DIN PN 16	900 x 200	415	470	184	268	344	16	295	250	275	22	28	1	—
495903900250T	ISO/DIN PN 16	900 x 250	440	470	204	320	410	16	355	250	275	26	33	1	—
495903900300T	ISO/DIN PN 16	900 x 300	510	530	257	370	467	16	410	250	275	26	40	1	—
495903900400T	ISO/DIN PN 16	900 x 400	550	610	327	482	595	16	525	250	280	30	54	1	—
4959031000100T	ISO/DIN PN 10/16	1000 x 100	320	300	101	158	220	16	180	102	120	18	24	4	—
4959031000150T	ISO/DIN PN 10/16	1000 x 150	320	300	131	212	285	16	240	113	131	22	24	1	—
4959031000200T	ISO/DIN PN 16	1000 x 200	443	470	184	268	344	16	295	250	275	22	28	1	—
4959031000250T	ISO/DIN PN 16	1000 x 250	443	470	204	320	410	16	355	250	275	26	33	1	—
4959031000300T	ISO/DIN PN 16	1000 x 300	516	530	257	370	467	16	410	250	275	26	40	1	—
4959031000400T	ISO/DIN PN 16	1000 x 400	563	610	327	482	595	16	525	250	280	30	54	1	—
4959031200100T	ISO/DIN PN 10/16	1200 x 100	320	300	101	158	220	16	180	102	120	18	24	1	—
4959031200150T	ISO/DIN PN 10/16	1200 x 150	320	300	131	212	285	16	240	113	131	22	24	1	—
4959031200200T	ISO/DIN PN 16	1200 x 200	447	470	184	268	344	16	295	250	275	22	28	1	—
4959031200250T	ISO/DIN PN 16	1200 x 250	447	470	204	320	410	16	355	250	275	26	33	1	—
4959031200300T	ISO/DIN PN 16	1200 x 300	526	530	257	370	467	16	410	250	275	26	40	1	—
4959031200400T	ISO/DIN PN 16	1200 x 400	574	610	327	482	595	16	525	250	280	30	54	1	—

* See "Large bore saddles installation tools" section at page 184 | * Consulte la sección "Herramientas de instalación de Tomas Simples/ Acometidas/Ramales de gran diámetro" en la página 184.

Flanged Branch Saddles for Pipes 125-150

4959X4

Collarín Bridado DN 100

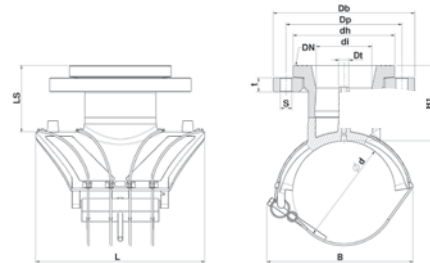

Product Code	d x DN	L	B	H1*	LS*	Db	Dp	dh	di	Dt	t	s	No. Holes
4959X4125100T	125X100	242	180	123	110	220	180	158	87	16	22	18	8
4959X4140100T	140X100	242	186	123	110	220	180	158	87	16	22	18	8
4959X4160100T	160X100	263	219	124	110	220	180	158	87	16	22	18	8
4959X4180100T	180X100	263	229	124	110	220	180	158	87	16	22	18	8
4959X4200100T	200X100	295	277	125	110	220	180	158	87	16	22	18	8
4959X4225100T	225X100	295	272	125	110	220	180	158	87	16	22	18	8
4959X4225150T	225X150	338	291	—	—	285	240	212	131	16	24	22	8
4959X4250100T	250X100	295	280	125	110	220	180	158	87	16	22	18	8
4959X4250150T	250X150	338	291	—	—	285	240	212	131	16	24	22	8

* May be customized according to customer's requirements.

Repair Saddle

495204

Collarín de reparación

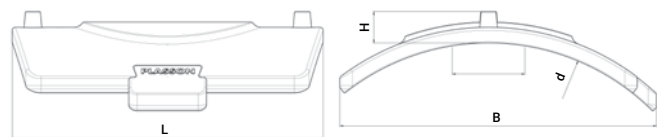

Product Code	Size d	B	H	L	Max Damage Length	UC	W
495204900070	250-900	305	30	300	70	16	1500
495203900230	400-900	471	43	610	230	3	6900

* See "Large bore saddles installation tools" section at page 184 | * Consulte la sección "Herramientas de instalación de Tomas Simples/ Acometidas/Ramales de gran diámetro" en la página 184.

Tapping Saddle

496304

Toma de Servicio



40mm up to 63mm 75mm up to 180mm 200mm up to 250mm

Product Code	Type*	Size d x d1	H	B	H1	H2	L	Welding Cap Type	UC	W
496304040020	mb	40 x 20	107	66	7	94	100	Type C	52	290
496304040025	mb	40 x 25	90	65	7	98	100	Type C	52	349
496304040032	mb	40 x 32	121	66	11	94	100	Type C	52	370
496304050020	mb	50 x 20	110	76	7	98	100	Type C	52	390
496304050025	mb	50 x 25	91	76	10	98	100	Type C	50	390
496304050032	mb	50 x 32	122	76	12	98	100	Type C	45	390
496304063020N	mb	63 x 20	90	100	10	90	118	Type C	40	362
496304063025N	mb	63 x 25	93	100	12	36	118	Type C	40	364
496304063032N	mb	63 x 32	99	100	12	90	118	Type C	40	369
496304063040		63 x 40	142	100	64	177	118	Type A	16	1080
496304063050		63 x 50	154	100	64	177	118	Type A	16	1099
496304063063		63 x 63	175	100	64	177	118	Type A	16	962
496304075020		75 x 20	125	117	50	177	118	Type A	16	1120
496304075032		75 x 32	132	117	56	177	118	Type A	16	1091
496304075040		75 x 40	142	117	60	177	118	Type A	16	1124
496304075050		75 x 50	123	117	64	177	118	Type A	16	1140
496304075063		75 x 63	175	117	64	177	118	Type A	16	1228
496304090020	mb	90 x 20	117	126	16	114	118	Type B	20	900
496304090025	mb	90 x 25	108	126	16	114	118	Type B	20	1120
496304090032	mb	90 x 32	126	126	16	114	118	Type B	20	778
496304090040	mb	90 x 40	134	126	21	114	118	Type B	20	1130
496304090050		90 x 50	123	126	64	177	118	Type A	14	1220
496304090063		90 x 63	175	126	64	177	118	Type A	14	1300

* Please note: mb = Mono Block | * Nota: mb = monobloque

Tapping Saddle

496304

Toma de Servicio

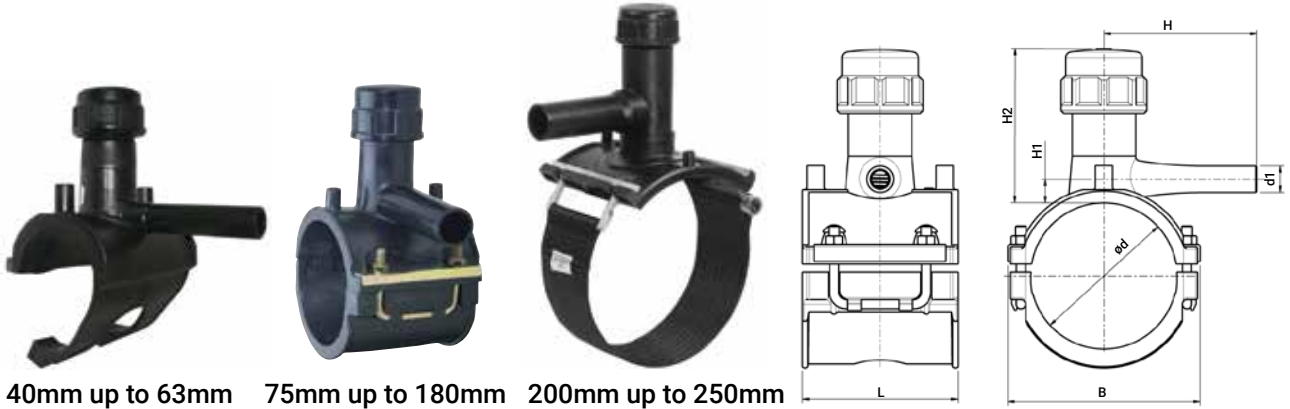

40mm up to 63mm 75mm up to 180mm 200mm up to 250mm

Product Code	Type*	Size d x d1	H	B	H1	H2	L	Welding Cap Type	UC	W
496304110020	mb	110 x 20	119	148	16	114	118	Type B	20	964
496304110025	mb	110 x 25	118	148	16	114	118	Type B	20	830
496304110032	mb	110 x 32	127	148	16	114	118	Type B	20	970
496304110040	mb	110 x 40	138	148	21	114	118	Type B	20	1000
496304110050		110 x 50	123	148	64	177	118	Type A	12	1300
496304110063		110 x 63	175	148	64	177	118	Type A	12	1383
496304125020	mb	125 x 20	116	162	16	114	118	Type B	15	1220
496304125025	mb	125 x 25	95	162	16	114	118	Type B	15	880
496304125032	mb	125 x 32	131	162	16	114	118	Type B	15	899
496304125040	mb	125 x 40	141	162	21	114	118	Type B	15	1280
496304125050		125 x 50	123	162	64	177	118	Type A	12	1345
496304125063		125 x 63	175	162	64	177	118	Type A	12	1426
496304140020		140 x 20	125	180	50	177	118	Type A	12	1340
496304140032		140 x 32	132	180	56	177	118	Type A	12	1330
496304140040		140 x 40	142	180	60	177	118	Type A	12	1360
496304140050		140 x 50	123	180	64	177	118	Type A	12	1382
496304140063		140 x 63	175	180	64	177	118	Type A	12	1468
496304160020	mb	160 x 20	118	199	21	138	118	Type A	10	1360
496304160025	mb	160 x 25	100	199	21	138	118	Type A	10	1170
496304160032	mb	160 x 32	144	199	16	138	118	Type A	10	1320
496304160040	mb	160 x 40	157	199	21	138	118	Type A	10	1216
496304160050	mb	160 x 50	175	199	24	138	118	Type A	10	1375
496304160063	mb	160 x 63	197	199	20	138	118	Type A	10	1390
496304180020		180 x 20	125	219	50	177	118	Type A	10	1550
496304180025	mb	180 x 25	110	219	18	138	118	Type A	10	1100
496304180032	mb	180 x 32	144	219	18	138	118	Type A	10	1565
496304180040	mb	180 x 40	155	219	21	138	118	Type A	10	1274
496304180050	mb	180 x 50	174	219	24	138	118	Type A	10	1595
496304180063	mb	180 x 63	197	219	20	138	118	Type A	10	1605
496304200020		200 x 20	125	202	50	177	176	Type A	8	1425
496304200032		200 x 32	132	202	56	177	176	Type A	8	1451
496304200040		200 x 40	142	202	60	177	176	Type A	8	1471
496304200050		200 x 50	123	202	64	177	176	Type A	8	1496
496304200063		200 x 63	175	202	64	177	176	Type A	8	1579
496304225020		225 x 20	125	227	50	177	176	Type A	8	1370
496304225032		225 x 32	132	227	56	177	176	Type A	8	1450
496304225040		225 x 40	142	227	60	177	176	Type A	8	1485
496304225050		225 x 50	123	227	64	177	176	Type A	8	1506
496304225063		225 x 63	175	227	64	177	176	Type A	8	1589
496304250020		250 x 20	125	252	50	177	176	Type A	8	1455
496304250032		250 x 32	132	252	56	177	176	Type A	8	1464
496304250040		250 x 40	142	252	60	177	176	Type A	8	1582
496304250050		250 x 50	123	252	64	177	176	Type A	8	1589
496304250063		250 x 63	175	252	64	177	176	Type A	8	1386

* Please note: mb = Mono Block | * Nota: mb = monobloque

Tapping Saddle Parallel Outlet

4963P4

Toma de Servicio salida Parallel Outlet

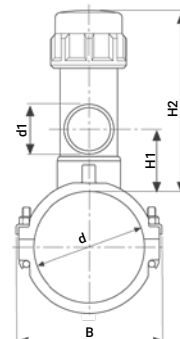
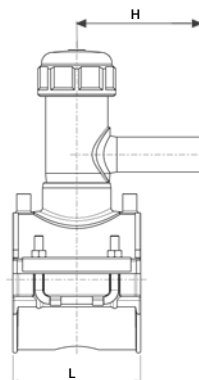

Product Code	Size d x d1	H	B	H1	H2	L	Welding Cap Type	UC	W
4963P4063020	63 x 20	125	100	50	177	118	Type A	16	—
4963P4063032	63 x 32	132	100	56	177	118	Type A	16	1042
4963P4063040	63 x 40	142	100	60	177	118	Type A	16	—
4963P4063050	63 x 50	123	100	64	177	118	Type A	16	906
4963P4063063	63 x 63	175	100	64	177	118	Type A	16	—
4963P4075020	75 x 20	125	117	50	177	118	Type A	16	—
4963P4075032	75 x 32	132	117	56	177	118	Type A	16	1120
4963P4075040	75 x 40	142	117	60	177	118	Type A	16	—
4963P4075050	75 x 50	123	117	64	177	118	Type A	16	—
4963P4075063	75 x 63	175	117	64	177	118	Type A	16	—
4963P4090020	90 x 20	125	126	50	177	118	Type A	14	—
4963P4090032	90 x 32	132	126	56	177	118	Type A	14	1120
4963P4090040	90 x 40	142	126	60	177	118	Type A	14	1130
4963P4090050	90 x 50	123	126	64	177	118	Type A	14	—
4963P4090063	90 x 63	175	126	64	177	118	Type A	14	—
4963P4110020	110 x 20	125	148	50	177	118	Type A	12	—
4963P4110032	110 x 32	132	148	56	177	118	Type A	12	1175
4963P4110040	110 x 40	142	148	60	177	118	Type A	12	1179
4963P4110050	110 x 50	123	148	64	177	118	Type A	12	1195
4963P4110063	110 x 63	175	148	64	177	118	Type A	12	1236
4963P4125020	125 x 20	125	162	50	177	118	Type A	10	—
4963P4125032	125 x 32	132	162	56	177	118	Type A	10	1298
4963P4125040	125 x 40	142	162	60	177	118	Type A	10	—
4963P4125050	125 x 50	123	162	64	177	118	Type A	10	—
4963P4125063	125 x 63	175	162	64	177	118	Type A	10	1430
4963P4140020	140 x 20	125	180	50	177	118	Type A	10	—
4963P4140032	140 x 32	132	180	56	177	118	Type A	10	—
4963P4140040	140 x 40	142	180	60	177	118	Type A	10	—
4963P4140050	140 x 50	123	180	64	177	118	Type A	10	1348
4963P4140063	140 x 63	175	180	64	177	118	Type A	10	—
4963P4160020	160 x 20	125	199	50	177	118	Type A	10	—
4963P4160032	160 x 32	132	199	56	177	118	Type A	10	1304
4963P4160040	160 x 40	142	199	60	177	118	Type A	10	1327
4963P4160050	160 x 50	123	199	64	177	118	Type A	10	1348
4963P4160063	160 x 63	175	199	64	177	118	Type A	10	1399
4963P4180020	180 x 20	125	219	50	177	118	Type A	8	—
4963P4180032	180 x 32	132	219	56	177	118	Type A	10	1304
4963P4180040	180 x 40	142	219	60	177	118	Type A	8	—
4963P4180050	180 x 50	123	219	64	177	118	Type A	8	—
4963P4180063	180 x 63	175	219	64	177	118	Type A	8	1304
4963P4200020	200 x 20	125	202	50	177	176	Type A	8	—
4963P4200032	200 x 32	132	202	56	177	176	Type A	8	1455
4963P4200040	200 x 40	142	202	60	177	176	Type A	8	—
4963P4200050	200 x 50	123	202	64	177	176	Type A	8	—
4963P4200063	200 x 63	175	202	64	177	176	Type A	8	1590
4963P4225020	225 x 20	125	227	50	177	176	Type A	8	—
4963P4225032	225 x 32	132	227	56	177	176	Type A	8	1455
4963P4225040	225 x 40	142	227	60	177	176	Type A	8	—
4963P4225050	225 x 50	123	227	64	177	176	Type A	8	—
4963P4225063	225 x 63	175	227	64	177	176	Type A	8	1455
4963P4250020	250 x 20	125	252	50	177	176	Type A	8	—
4963P4250032	250 x 32	132	252	56	177	176	Type A	8	1470
4963P4250040	250 x 40	142	252	60	177	176	Type A	8	—
4963P4250050	250 x 50	123	252	64	177	176	Type A	8	—
4963P4250063	250 x 63	175	252	64	177	176	Type A	8	1470

High Volume Tapping Tee (HVTT)

491304

Toma en carga de alto volumen

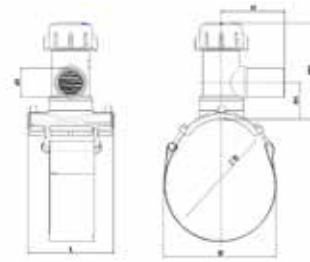

Product Code	size d x d1	B	L	H	H1	H2	Cutter Dia.	UC	W
491304090063	90 x 63	139	176	130	75	195	47	8	1965
491304110063	110 x 63	156	176	130	75	195	47	8	1960
491304125063	125 x 63	165	176	130	75	195	47	8	1935
491304140063	140 x 63	171	176	130	75	195	47	8	—
491304160063	160 x 63	173	176	130	75	195	47	8	1970
491304180063	180 x 63	176	176	130	75	195	47	8	1940
491304200063	200 x 63	178	176	130	75	195	47	8	—
491304225063	225 x 63	180	176	130	75	195	47	8	1970
491304250063	250 x 63	180	176	130	75	195	47	8	2000
491304280063	280 x 63	180	176	130	75	195	47	8	1975
491304315063	315 x 63	183	176	130	75	195	47	8	2010

Welding Cap for Tapping Saddle

498304

Tapón Soldable para toma de servicio

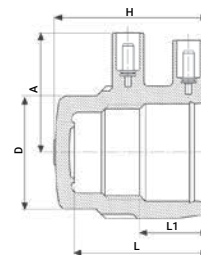

Product Code	Type	Size	D	A	H	L	L1	UC	W
498304057	Type A	57	74	59	74	63	36	128	157
498304050	Type B	50	62	54	73	66	30	192	111
498304040	Type C	40	51	49	63	55	26	256	73

PE Ball Valve

436207

Válvula de Bola PE

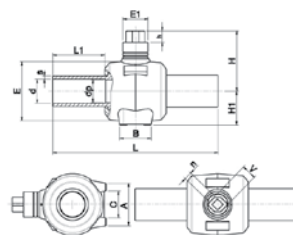

Product Code	Size d	dp	s	L	L1	B	E	E1	H	H1	h	C	V	U	UC	W
436207025	25*	19	3	300	103	65	80	70	94	50	40	39	50	26	12	705
436207032	32*	24	3	300	103	65	80	70	94	50	40	39	50	26	12	855
436207040	40	24	4	300	103	65	80	70	94	50	40	39	50	26	12	758
436207050	50*	39	6	414	130	87	120	85	160	80	40	54	50	26	4	2091
436207063	63*	48	6	414	130	87	120	85	160	80	40	54	50	26	4	2061
436207075	75	48	8	414	130	87	120	85	160	80	40	54	50	26	4	2558
436207090	90*	70	8	550	176	93	200	85	200	110	40	90	50	26	2	5865
436207110	110*	86	10	550	178	93	200	85	200	110	40	90	50	26	2	5761
436207125	125	86	12	550	182	93	200	85	200	110	40	90	50	26	2	6400
436207160	160	86	16	550	182	93	200	85	200	110	40	90	50	26	2	7100

* Full Bore Dimensions | * Dimensiones de cavidad única

PE Ball Valve with Two Purges

436Q7

PE Ball Válvula de Bola con purga

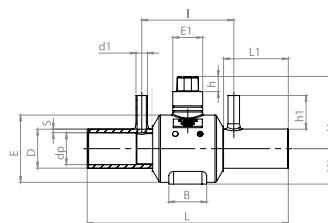

Product Code	Size d	d1	A	H	H1	L	L1	B	Dp	S	I	E	E1	h	c	UC	W
4362Q7090	90	32	146	200	110	550	176	107	70	9	251	187	85	40	90	2	5606
4362Q7110	110	32	146	200	110	550	176	107	84	10	251	188	85	40	90	2	5784

Tapping Valve

4954S4*/495404

Toma de Servicio con Válvula



63mm up to 180mm



200mm up to 250mm

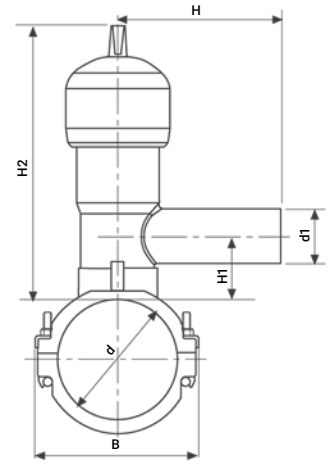

Product Code	Size d x d1	B	H	H1	H2	L	UC	W
495404063032	63 x 32	99	126	46	244	118	8	2090
495404063040	63 x 40	99	137	46	244	118	8	2103
495404063050	63 x 50	99	152	51	244	118	8	2140
495404063063	63 x 63	99	186	51	244	118	8	2205
495404075032	75 x 32	117	126	46	244	118	8	2100
495404075040	75 x 40	117	137	46	244	118	8	2113
495404075050	75 x 50	117	152	51	244	118	8	2150
495404075063	75 x 63	117	186	51	244	118	8	2215
495404090032	90 x 32	126	126	46	244	118	8	2150
495404090040	90 x 40	126	137	46	244	118	8	2163
495404090050	90 x 50	126	152	51	244	118	8	2200
495404090063	90 x 63	126	186	51	244	118	8	2265
495404110032	110 x 32	148	126	46	244	118	8	2267
495404110040	110 x 40	148	137	46	244	118	8	2250
495404110050	110 x 50	148	152	51	244	118	8	2280
495404110063	110 x 63	148	186	51	244	118	8	2345
495404125032	125 x 32	162	126	46	244	118	8	2277
495404125040	125 x 40	162	137	46	244	118	8	2290
495404125050	125 x 50	162	152	51	244	118	8	2327
495404125063	125 x 63	162	186	51	244	118	8	2392
495404140032	140 x 32	180	126	46	244	118	8	2285
495404140040	140 x 40	180	137	46	244	118	8	2298
495404140050	140 x 50	180	152	51	244	118	8	2335
495404140063	140 x 63	180	186	51	244	118	8	2441
495404160032	160 x 32	202	126	46	244	118	8	2377
495404160040	160 x 40	202	137	46	244	118	8	2390
495404160050	160 x 50	202	152	51	244	118	8	2427
495404160063	160 x 63	202	186	51	244	118	8	2492
495404180032	180 x 32	220	126	46	244	118	8	2440
495404180040	180 x 40	220	137	46	244	118	8	2453
495404180050	180 x 50	220	152	51	244	118	8	2490
495404180063	180 x 63	220	186	51	244	118	8	2555
495404200032	200 x 32	202	126	46	244	176	5	2431
495404200040	200 x 40	202	137	46	244	176	5	2444
495404200050	200 x 50	202	152	51	244	176	5	2481
495404200063	200 x 63	202	186	51	244	176	5	2546
495404225032	225 x 32	227	126	46	244	176	5	2448
495404225040	225 x 40	227	137	46	244	176	5	2501
495404225050	225 x 50	227	152	51	244	176	5	2538
495404225063	225 x 63	227	186	51	244	176	5	2603
495404250032	250 x 32	252	126	46	244	176	5	2504
495404250040	250 x 40	252	137	46	244	176	5	2517
495404250050	250 x 50	252	152	51	244	176	5	2554
495404250063	250 x 63	252	186	51	244	176	5	2619

* Tapping Valve with serrated edge cutter.

* Toma de servicio con bordes "dientes de sierra".

PLASSON PA Threads

- ✓ Corrosion free
- ✓ Ideal for handling high-pressure environments, stresses and heavy loads
- ✓ Smooth assembly and disassembly, reducing the risk of thread damage
- ✓ Suitable for outdoor applications
- ✓ Suitable for professionals and DIY enthusiasts alike



PA Male Transition Coupler

4921N4

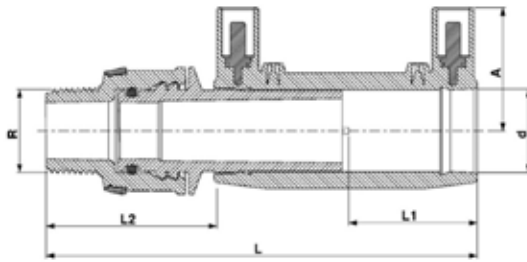

Product Code	Size d x R	L	L1	L2	A	UB	UC	W
4921N4020005	20 x 1/2"	128	37	52	35			
4921N4020007	20 x 3/4"	129	37	53	35			
4921N4020010	20 x 1"	131	37	55	35			
4921N4025005	25 x 1/2"	132	40	49	37			
4921N4025007	25 x 3/4"	133	40	50	37			
4921N4025010	25 x 1"	135	40	52	37			
4921N4032007	32 x 3/4"	156	44	66	41			
4921N4032010	32 x 1"	158	44	68	41			
4921N4032013	32 x 1 1/4"	161	44	71	41			
4921N4032015	32 x 1 1/2"	161	44	71	41			
4921N4032020	32 x 2"	166	44	76	41			
4921N4040007	40 x 3/4"	162	48	64	46			
4921N4040010	40 x 1"	164	48	66	46			
4921N4040013	40 x 1 1/4"	167	48	69	46			
4921N4040015	40 x 1 1/2"	167	48	69	46			
4921N4040020	40 x 2"	172	48	74	46			
4921N4050013	50 x 1 1/4"	190	50	88	51			
4921N4050015	50 x 1 1/2"	190	50	88	51			
4921N4050020	50 x 2"	194	50	92	51			
4921N4063013	63 x 1 1/4"	205	58	87	58			
4921N4063015	63 x 1 1/2"	205	58	87	58			
4921N4063020	63 x 2"	209	58	91	58			

PA Male Transition Adaptor

4921N7

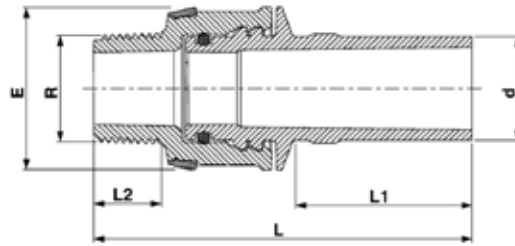

Product Code	Size d x R	E	L	L1	L2	UB	UC	W
4921N7020005	20 x 1/2"	40	89	42	16			
4921N7020007	20 x 3/4"	40	90	42	17			
4921N7020010	20 x 1"	40	92	42	18			
4921N7025005	25 x 1/2"	40	89	42	20			
4921N7025007	25 x 3/4"	40	90	42	17			
4921N7025010	25 x 1"	40	92	42	18			
4921N7032007	32 x 3/4"	56	110	47	20			
4921N7032010	32 x 1"	56	112	47	18			
4921N7032013	32 x 1 1/4"	56	115	47	20			
4921N7032015	32 x 1 1/2"	56	115	47	22			
4921N7032020	32 x 2"	61	120	47	22			
4921N7040007	40 x 3/4"	56	112	52	26			
4921N7040010	40 x 1"	56	114	52	18			
4921N7040013	40 x 1 1/4"	56	116	52	20			
4921N7040015	40 x 1 1/2"	56	116	52	22			
4921N7040020	40 x 2"	61	122	52	22			
4921N7050013	50 x 1 1/4"	80	138	57	26			
4921N7050015	50 x 1 1/2"	80	138	57	22			
4921N7050020	50 x 2"	80	142	57	22			
4921N7063013	63 x 1 1/4"	80	144	65	26			
4921N7063015	63 x 1 1/2"	80	144	65	22			
4921N7063020	63 x 2"	80	148	65	22			

90° PA Male Elbow

4925N4

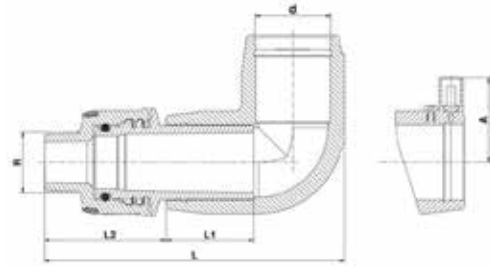

Product Code	Size d x R	L	L1	L2	A	UB	UC	W
4925N4020005	20 x 1/2"	124	35	54	54			
4925N4020007	20 x 3/4"	125	35	55	54			
4925N4020010	20 x 1"	127	35	57	54			
4925N4025005	25 x 1/2"	124	35	44	54			
4925N4025007	25 x 3/4"	125	35	55	54			
4925N4025010	25 x 1"	127	35	57	54			
4925N4032007	32 x 3/4"	150	44	66	41			
4925N4032010	32 x 1"	152	44	68	41			
4925N4032013	32 x 1 1/4"	155	44	71	41			
4925N4032015	32 x 1 1/2"	155	44	71	41			
4925N4032020	32 x 2"	160	44	76	41			
4925N4040007	40 x 3/4"	164	48	67	45			
4925N4040010	40 x 1"	166	48	69	45			
4925N4040013	40 x 1 1/4"	168	48	71	45			
4925N4040015	40 x 1 1/2"	168	48	71	45			
4925N4040020	40 x 2"	174	48	77	45			
4925N4050013	50 x 1 1/4"	199	49	89	50			
4925N4050015	50 x 1 1/2"	199	49	89	50			
4925N4050020	50 x 2"	203	49	93	50			
4925N4063013	63 x 1 1/4"	218	58	86	56			
4925N4063015	63 x 1 1/2"	218	58	86	56			
4925N4063020	63 x 2"	222	58	90	56			

45° PA Male Elbow

4926N4

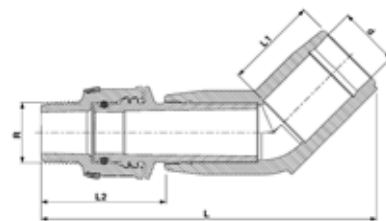

Product Code	Size d x R	L	L1	L2	A	UB	UC	W
4926N4032007	32 x 3/4"	169	44	66	41			
4926N4032010	32 x 1"	171	44	68	41			
4926N4032013	32 x 1 1/4"	174	44	71	41			
4926N4032015	32 x 1 1/2"	174	44	71	41			
4926N4032020	32 x 2"	179	44	76	41			
4926N4040007	40 x 3/4"	182	48	67	45			
4926N4040010	40 x 1"	184	48	69	45			
4926N4040013	40 x 1 1/4"	186	48	71	45			
4926N4040015	40 x 1 1/2"	186	48	71	45			
4926N4040020	40 x 2"	192	48	77	45			
4926N4050013	50 x 1 1/4"	214	49	89	50			
4926N4050015	50 x 1 1/2"	214	49	89	50			
4926N4050020	50 x 2"	218	49	93	50			
4926N4063013	63 x 1 1/4"	236	58	86	56			
4926N4063015	63 x 1 1/2"	236	58	86	56			
4926N4063020	63 x 2"	240	58	90	56			

Male Transition Coupler

492104

Enlace de Transición Macho



Type A

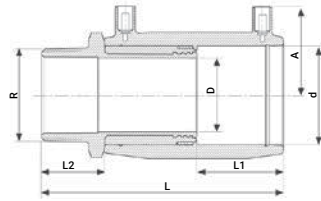

Type B

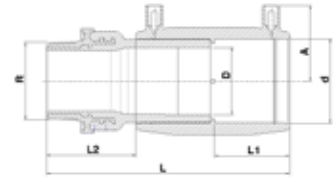

Product Code	Size d x R	Type	L	L1	L2	D	A	UC	W
492104020005	20 x 1/2"	A	105	37	29	14	34	200	129
492104025007	25 x 3/4"	A	111	40	29	19	37	150	150
492104032005	32 x 1/2"	A	110	39	29	23	42	100	142
492104032007	32 x 3/4"	A	110	39	29	23	42	100	263
492104032010N	32 x 1"	B	140	44	50	22	43	100	285
492104032013	32 x 1 1/4"	A	124	42	36	23	42	60	393
492104032015	32 x 1 1/2"	A	124	42	36	23	42	60	404
492104040010N	40 x 1"	B	143	48	45	22	46	72	409
492104040013N	40 x 1 1/4"	B	153	48	55	30	46	54	470
492104040015	40 x 1 1/2"	A	133	47	36	29	46	54	483
492104040020N	40 x 2"	B	160	44	41	29	59	36	500
492104050010	50 x 1"	A	135	49	34	38	51	48	513
492104050013	50 x 1 1/4"	A	137	49	36	38	51	48	569
492104050015N	50 x 1 1/2"	B	164	49	63	35	51	48	547
492104050020N	50 x 2"	B	160	49	41	38	59	30	752
492104063013	63 x 1 1/4"	A	153	57	36	48	57	30	884
492104063015	63 x 1 1/2"	A	153	57	36	48	57	30	845
492104063020N	63 x 2"	B	186	57	69	47	58	30	921
492104075020	75 x 2"	A	167	61	41	59	64	16	1305
492104075025	75 x 2 1/2"	A	172	61	46	59	64	16	1512

Female Transition Coupler

493104

Enlace de Transición Hembra



Type A

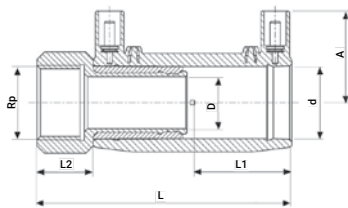

Type B

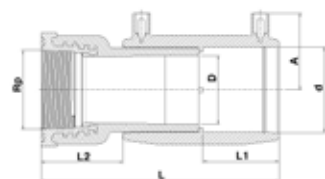

Product Code	Size d x Rp	Type	L	L1	L2	D	A	UC	W
493104020005	20 x 1/2"	A	96	37	20	14	35	200	130
493104025007	25 x 3/4"	A	105	40	23	19	38	150	145
493104025010N	25 x 1"	B	108	34	28	23	42	80	252
493104032007	32 x 3/4"	A	124	39	23	19	42	100	159
493104032010N	32 x 1"	B	130	44	40	27	43	100	265
493104032013	32 x 1 1/4"	A	118	39	28	29	47	54	507
493104032015	32 x 1 1/2"	A	124	39	25	38	47	50	455
493104040010	40 x 1"	A	122	47	25	29	46	54	507
493104040013	40 x 1 1/4"	A	122	47	25	29	46	54	407
493104040015	40 x 1 1/2"	A	122	47	25	29	46	48	419
493104040020N	40 x 2"	B	150	44	32	38	59	32	821
493104050015	50 x 1 1/2"	A	126	49	25	38	51	48	491
493104050020	50 x 2"	A	131	49	30	38	51	40	685
493104063015	63 x 1 1/2"	A	145	59	26	38	59	24	558
493104063020N	63 x 2"	B	179	57	62	49	58	30	840

Male Transition Elbow 90°

492504

Codo de Transición de 90° Macho

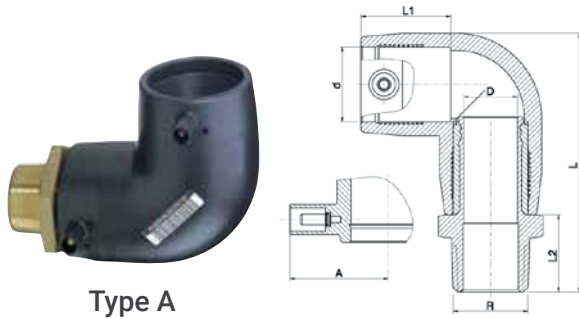

Type A



Type B

Product Code	Size d x R	Type	L	L1	L2	D	A	UC	W
492504020005	20 x 1/2"	A	95	35	29	14	38	150	153
492504025007	25 x 3/4"	A	95	37	29	19	38	120	168
492504032005	32 x 1/2"	A	112	40	29	23	43	84	294
492504032007	32 x 3/4"	A	112	40	29	23	43	84	262
492504032010N	32 x 1"	B	134	44	49	22	47	84	300
492504032013	32 x 1 1/4"	A	119	40	36	23	43	60	419
492504032015	32 x 1 1/2"	A	119	40	36	23	43	60	436
492504040010N	40 x 1"	B	142	44	49	22	47	48	458
492504040013N	40 x 1 1/4"	B	153	44	59	30	47	48	500
492504040015	40 x 1 1/2"	A	128	44	36	29	47	48	510
492504040020	40 x 2"	A	133	44	41	29	47	48	725
492504050010	50 x 1"	A	142	48	34	38	52	42	624
492504050013	50 x 1 1/4"	A	144	48	36	38	52	36	679
492504050015N	50 x 1 1/2"	B	174	49	63	35	52	36	655
492504050020	50 x 2"	A	149	48	41	38	52	30	806
492504063013	63 x 1 1/4"	A	167	57	36	48	59	24	985
492504063015	63 x 1 1/2"	A	167	57	36	48	59	24	1040
492504063020N	63 x 2"	B	200	58	68	47	57	24	1015
492504075020	75 x 2"	A	199	69	41	59	62	16	1450
492504075025	75 x 2 1/2"	A	204	69	46	59	62	16	1649

Female Transition Elbow 90°

493504

Codo de Transición de 90° Hembra

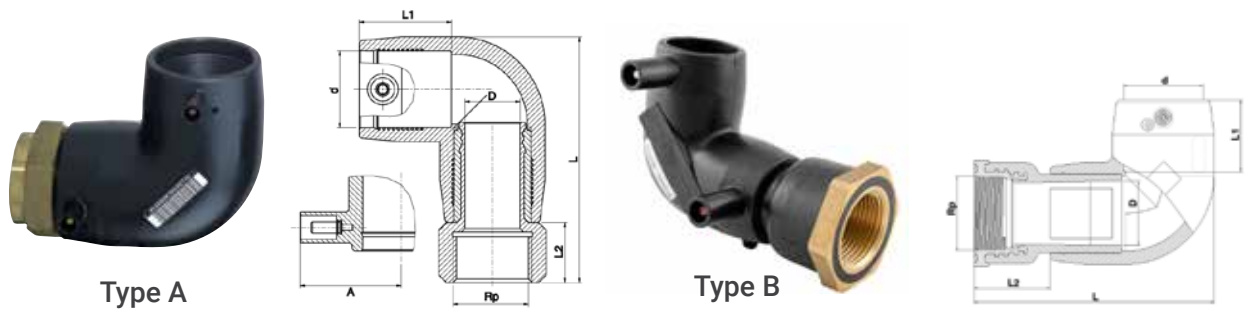

Product Code	Size d x Rp	Type	L	L1	L2	D	A	UC	W
493504020005	20 x 1/2"	A	86	35	20	14	38	160	142
493504025007	25 x 3/4"	A	89	37	23	19	38	120	160
493504032007	32 x 3/4"	A	108	40	25	23	43	96	280
493504032010N	32 x 1"	B	123	39	42	27	42	96	280
493504032015	32 x 1 1/2"	A	108	40	25	23	43	96	360
493504040010	40 x 1"	A	117	44	25	29	47	48	535
493504040013	40 x 1 1/4"	A	117	44	25	29	47	48	432
493504040015	40 x 1 1/2"	A	117	44	25	29	47	48	453
493504050015	50 x 1 1/2"	A	133	48	25	38	52	48	560
493504050020	50 x 2"	A	138	48	30	38	52	40	744
493504063015	63 x 1 1/2"	A	161	57	30	48	59	24	1072
493504063020N	63 x 2"	B	193	58	62	49	57	24	959

Male Transition Elbow 45°

492604

Codo de Transición de 45° Macho

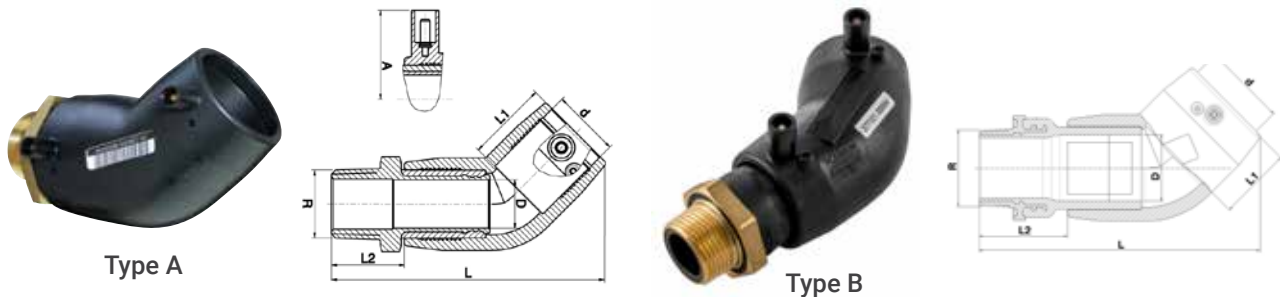

Product Code	Size d x R	Type	L	L1	L2	D	A	UC	W
492604032005	32 x 1/2"	A	124	39	29	23	43	84	249
492604032007	32 x 3/4"	A	123	39	29	23	43	84	250
492604032010N	32 x 1"	B	151	39	50	22	42	72	375
492604032013	32 x 1 1/4"	A	130	39	36	23	43	48	479
492604032015	32 x 1 1/2"	A	130	39	36	23	43	48	488
492604040010N	40 x 1"	B	158	48	45	22	47	60	433
492604040013N	40 x 1 1/4"	B	168	48	55	30	47	60	485
492604040015	40 x 1 1/2"	A	144	44	36	29	47	48	510
492604040020	40 x 2"	A	149	44	41	29	47	40	685
492604050010	50 x 1"	A	161	49	34	38	51	48	564
492604050013	50 x 1 1/4"	A	161	49	36	38	51	48	610
492604050015N	50 x 1 1/2"	B	185	49	63	35	52	48	600
492604050020	50 x 2"	A	165	49	41	38	51	30	778
492604063013	63 x 1 1/4"	A	184	57	36	48	59	24	927
492604063015	63 x 1 1/2"	A	184	57	36	48	59	24	893
492604063020N	63 x 2"	B	215	58	68	47	57	24	953
492604075020	75 x 2"	A	221	71	41	59	62	16	1399
492604075025	75 x 2 1/2"	A	226	71	46	59	62	16	1600

Female Transition Elbow 45°

493604

Codo de Transición de 45° Hembra

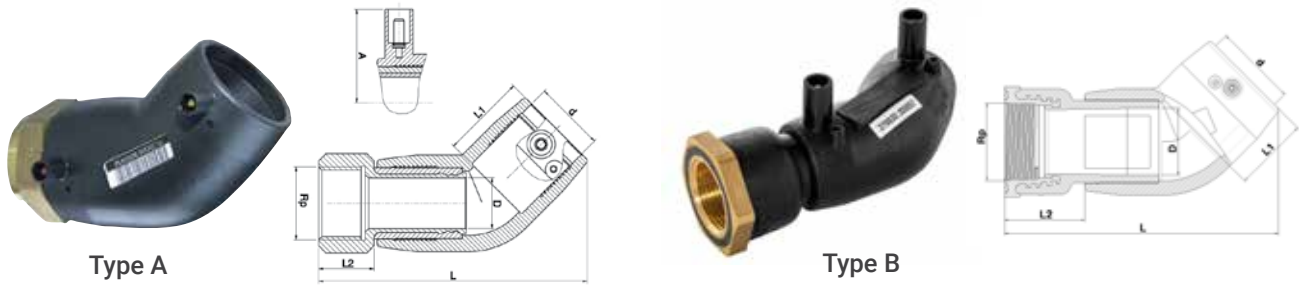

Product Code	Size d x Rp	Type	L	L1	L2	D	A	UC	W
493604032007	32 x 3/4"	A	120	39	25	23	43	—	320
493604032010N	32 x 1"	B	141	44	40	27	42	72	342
493604032015	32 x 1 1/2"	A	120	39	25	23	43	72	488
493604040010	40 x 1"	A	133	44	25	29	47	48	510
493604040013	40 x 1 1/4"	A	133	44	25	29	47	48	419
493604040015	40 x 1 1/2"	A	133	44	25	29	47	48	479
493604050015	50 x 1 1/2"	A	150	49	25	38	51	48	532
493604050020	50 x 2"	A	155	49	30	38	51	36	702
493604063015	63 x 1 1/2"	A	178	57	30	48	59	24	1019
493604063020N	63 x 2"	B	208	58	62	49	57	24	912

Female Free Nut Transition Coupler*

494104

Enlace de Transición, Tuerca Libre, Hembra



Product Code	Size d x G	L	L1	L2	D	A	UC	W
494104020007	20 x 3/4"	106	37	30	14	34	200	160
494104025007	25 x 3/4"	112	40	30	14	37	140	150
494104025010	25 x 1"	115	40	33	19	37	140	200
494104032007	32 x 3/4"	100	39	20	14	42	100	164
494104032010	32 x 1"	124	42	36	19	42	100	260
494104032013	32 x 1 1/4"	124	42	36	23	42	78	310
494104040010	40 x 1"	115	44	25	19	47	100	278
494104040013	40 x 1 1/4"	113	44	23	23	47	52	320
494104040015	40 x 1 1/2"	135	47	38	29	45	52	444
494104050010	50 x 1"	136	49	36	19	52	32	700
494104050013	50 x 1 1/4"	120	49	23	23	52	70	371
494104050015	50 x 1 1/2"	123	49	25	29	52	32	484
494104050020	50 x 2"	141	49	41	38	52	32	709
494104063020	63 x 2"	161	57	44	38	57	28	770
494104063025	63 x 2 1/2"	166	57	49	48	57	20	1154

* May be converted into male free nut by addition of a threaded nipple.

* Se puede convertir en la tuerca loca macho mediante la adición de un niple roscado.

Female Free Nut Transition Elbow 90°*

494504

Codo de Transición de 90° Tuerca Libre, Hembra

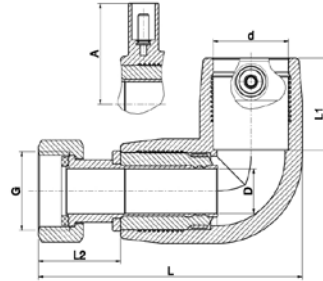

Product Code	Size d x G	L	L1	L2	D	A	UC	W
494504020007	20 x 3/4"	96	35	30	14	38	140	164
494504025007	25 x 3/4"	96	37	30	14	38	140	164
494504025010	25 x 1"	99	37	33	19	38	105	164
494504032010	32 x 1"	119	40	36	19	43	70	164
494504032013	32 x 1 1/4"	119	40	36	23	43	70	324
494504040015	40 x 1 1/2"	132	44	40	29	47	48	490
494504050020	50 x 2"	149	48	41	38	52	30	779
494504063020	63 x 2"	175	57	44	41	59	16	1024
494504063025	63 x 2 1/2"	180	57	49	48	59	16	1245

* May be converted into male free nut by addition of a threaded nipple.

* Se puede convertir en la tuerca loca macho mediante la adición de un niple roscado.

Female Free Nut Transition Elbow 45°*

494604

Codo de Transición de 45° Tuerca Libre, Hembra

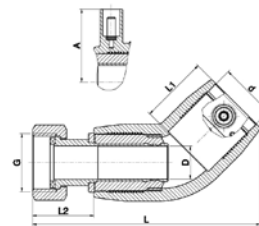

Product Code	Size d x G	L	L1	L2	D	A	UC	W
494604032010	32 x 1"	131	39	36	19	43	70	164
494604032013	32 x 1 1/4"	129	39	34	23	47	56	400
494604040015	40 x 1 1/2"	146	44	38	29	47	48	469
494604050020	50 x 2"	166	49	41	38	51	30	740
494604063020	63 x 2"	189	57	41	38	59	24	164
494604063025	63 x 2 1/2"	197	57	44	48	59	16	1184

* May be converted into male free nut by addition of a threaded nipple.

* Se puede convertir en la tuerca loca macho mediante la adición de un niple roscado.

Female Union Free Nut Transition Tee

494404

Enlace T, PE/Latón, Tuerca Libre, Hembra

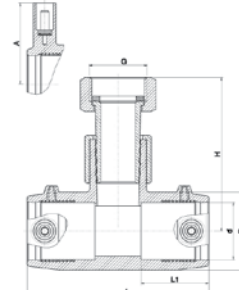

Product Code	Size d x G	L	L1	D	H	A	UC	W
494404032010	32 x 1"	104	39	44	88	43	50	320

PE Male Transition Coupler

497104

Enlace de Transición PE Macho

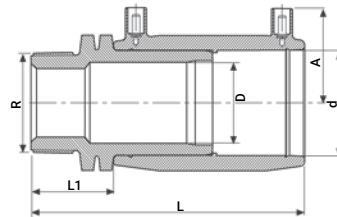

Product Code	Size d x R	L	L1	D	A	UC	W
497104020005	20 x 1/2"	97	21	14	34	200	129
497104025007	25 x 3/4"	113	31	18	37	200	61
497104032010	32 x 1"	123	35	24	42	200	92
497104040010	40 x 1"	134	37	30	46	128	146
497104040013	40 x 1 1/4"	137	40	30	46	128	152
497104040015	40 x 1 1/2"	137	40	30	46	128	159
497104050015	50 x 1 1/2"	141	40	38	51	96	238
497104063015	63 x 1 1/2"	161	44	48	57	40	371
497104063020	63 x 2"	165	48	48	57	40	450

PE Male Transition Elbow 90°

497504

Codo de Transición PE de 90° Macho

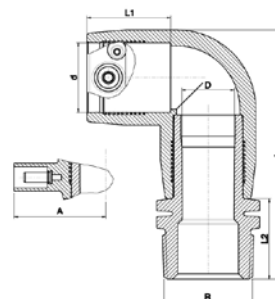

Product Code	Size d x R	L	L1	D	A	L2_Cap	UC	W
497504020005	20 x 1/2"	87	35	14	38	21	160	78
497504025007	25 x 3/4"	97	37	18	38	31	200	75
497504032010	32 x 1"	118	40	24	43	35	96	120
497504040010	40 x 1"	129	44	30	47	37	48	458
497504040013	40 x 1 1/4"	132	44	30	47	40	48	202
497504040015	40 x 1 1/2"	132	44	30	47	40	48	250
497504050015	50 x 1 1/2"	148	48	38	52	40	48	296
497504063015	63 x 1 1/2"	175	57	48	59	44	44	458
497504063020	63 x 2"	179	57	48	59	48	44	490

PE Male Transition Elbow 45°

497604

Codo de Transición PE de 45° Macho

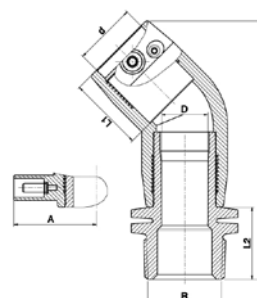

Product Code	Size d x R	L	L1	D	A	L2_Cap	UC	W
497604032010	32 x 1"	141	39	24	43	35	96	150
497604040010	40 x 1"	145	42	30	47	37	96	175
497604040013	40 x 1 1/4"	148	42	30	47	40	96	185
497604040015	40 x 1 1/2"	148	42	30	47	40	96	185
497604050015	50 x 1 1/2"	165	49	38	51	40	48	271
497604063015	63 x 1 1/2"	192	57	48	59	44	24	465
497604063020	63 x 2"	196	57	48	59	48	24	470

PE Cast Iron Flange Transition Coupler

497704

Enlace de Transición Bridado - PE Hierro Fundido

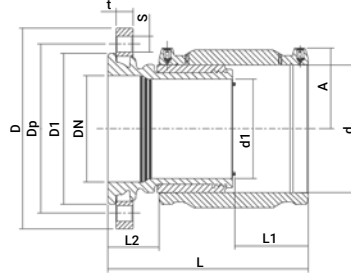

Product Code	Size d x DN	A	L	L1	L2	D1	d1	D	Dp	s	t	No. of holes	UC	W
497704063	63 x 50	57	217	57	100	104	43	165	125	18	20	4	4	4200
497704090	90 x 80	70	216	73	68	139	67	200	160	18	20	8	4	5779
497704110	110 x 100	79	223	80	61	159	84	220	180	18	22	8	4	7280
497704125	125 x 100	87	235	85	62	159	98	220	180	18	22	8	4	7759
497704160	160 x 150	105	268	93	73	215	125	285	240	22	24	8	1	13400
497704180	180 x 150	116	284	105	72	215	140	285	240	22	24	8	1	15246
497704225	225 x 200	138	314	119	74	270	176	340	295	22	26	12	1	23919

PE Cast Iron Spigot Transition Coupler

495704

Enlace de Transición Espiga - PE Hierro Fundido

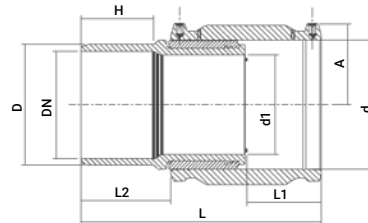

Product Code	Size d x DN	A	L	L1	L2	D	d1	H	UC	W
495704090080	90 x 80	69	254	73	106	98	67	94	8	2874
495704110100	110 x 100	79	275	80	112	118	84	96	4	4170
495704125100	125 x 100	87	280	85	107	118	98	91	4	4569
495704160150	160 x 150	104	322	97	124	170	125	102	2	8105
495704180150	180 x 150	114	339	104	127	170	140	103	2	10121
495704225200	225 x 200	140	372	118	132	222	176	109	1	12284

Full Face Flange

490209

Brida de Cara Plana

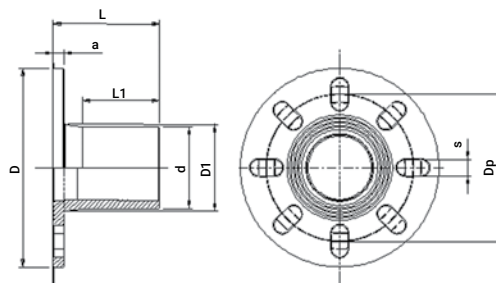

Product Code	Size d	L	L1	D	D1	a	Dp	s	UC	W
490209090	90	118	86	220	98	12	163	20	18	540

Stub Flange

490207

Adaptador de Brida

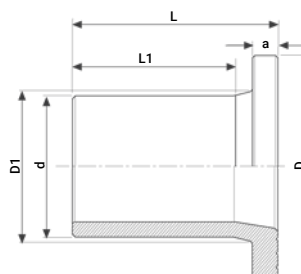

Product Code	Size d	L	L1	a	D	D1	UC	W
490207020	20	85	45	7	45	26	160	26
490207025	25	85	40	9	58	32	160	42
490207032	32	85	60	10	68	40	160	59
490207040	40	85	60	11	78	50	160	84
490207050	50	104	75	12	88	61	144	104
490207063	63	120	87	14	102	75	60	220
490207075	75	130	92	16	122	89	48	322
490207090	90	140	96	17	138	105	32	475
490207110	110	160	110	18	158	125	20	643
490207125	125	182	132	25	158	132	16	945
490207140	140	180	130	25	188	155	12	1245
490207160	160	180	130	25	212	175	8	1600
490207180	180	198	140	30	212	187	4	1990
490207200	200	200	135	32	268	232	4	3100
490207225	225	200	135	32	268	235	4	3360
490207250	250	215	145	35	320	285	3	5080
490207280	280	228	160	35	320	291	2	5688
490207315	315	238	160	35	370	335	1	7785
490207355	355	255	175	40	430	373	1	10400
490207400	400	286	195	45	482	427	1	14970

Flange Backing Ring

09903

Brida Revestida

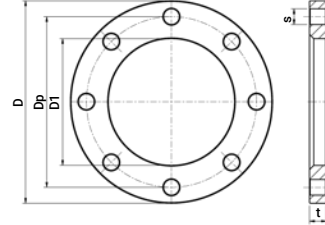

Product Code	Flange Type	Flange (DN)	D	Dp	D1	s	t	No. of Holes	UC	W
09903020	ISO/DIN PN 10/16	20 x 1/2" (DN15)	95	65	28	14	12	4	200	240
09903025	ISO/DIN PN 10/16	25 x 3/4" (DN20)	105	75	34	14	14	4	180	300
09903032	ISO/DIN PN 10/16	32 x 1" (DN25)	115	85	42	14	16	4	150	495
09903040	ISO/DIN PN 10/16	40 x 1 1/4" (DN32)	140	100	51	18	18	4	120	685
09903050	ISO/DIN PN 10/16	50 x 1 1/2" (DN40)	150	110	62	18	18	4	100	812
09903063	ISO/DIN PN 10/16	63 x 2" (DN50)	165	125	78	18	17	4	20	1110
09903075	ISO/DIN PN 10/16	75 x 2 1/2" (DN65)	185	145	92	18	18	4	20	1205
09902095	ISO/DIN PN 10/16	90 x 2 1/2" (DN65)	185	145	102	18	20	8	100	2,552
09903090	ISO/DIN PN 10/16	90 x 3" (DN80)	200	160	108	18	20	8	20	1400
09903110	ISO/DIN PN 10/16	110 x 4" (DN100)	220	180	128	18	20	8	20	1570
09903125	ISO/DIN PN 10/16	125 x 4" (DN100)	220	180	135	18	20	8	40	1470
09903140	ISO/DIN PN 10/16	140 x 5" (DN125)	250	210	158	18	24	8	30	1930
09903160	ISO/DIN PN 10/16	160 x 6" (DN150)	285	240	178	22	24	8	6	3625
09903180	ISO/DIN PN 10/16	180 x 6" (DN150)	285	240	188	22	24	8	10	2150
09903200	ISO/DIN PN 10	200 x 8" (DN200)	340	295	236	22	24	8	4	3600
09903225	ISO/DIN PN 10	225 x 8" (DN200)	340	295	239	22	24	8	8	3510
09903250	ISO/DIN PN 10	250 x 10" (DN250)	395	350	288	22	30	12	8	5200
09901250	BS 10 Table D	250 x 10" BS	395	355	288	22	26	8	1	10,055
09903280	ISO/DIN PN 10	280 x 10" (DN250)	395	350	294	22	30	12	8	5500
09901280	BS 10 Table D	280 x 10" BS	395	355	294	22	26	8	1	10,055
09903315	ISO/DIN PN 10	315 x 12" (DN300)	445	400	338	22	34	12	3	8350
09901315	BS 10 Table D	315 x 12" BS	445	406	338	22	26	12	1	10,055
09903355	ISO/DIN PN 10	355 x 14"	—	460	376	—	39	16	2	20000
09901355	BS 10 Table D	355 x 14" BS	520	470	376	26	28	12	1	10,055

Wastewater System, We Make the Connection

Polyethylene offers the ideal cost-effective and technically superior alternative to other materials, requiring minimal effort to install, reducing the number of connections required and increasing the system lifespan.

The PLASSON System constitutes an excellent investment for both public wastewater infrastructures and private wastewater systems

The PLASSON wastewater system offers a strong, long-life and is resistant to axial loads through its special versatile products that can be completely fused after being laid.



Systemas de Aguas Residuales, Hacemos la Conexión

En comparación con otros materiales, el polietileno constituye la alternativa ideal en términos de costo-beneficio y superioridad técnica, ya que requiere un mínimo esfuerzo de instalación, con menos conexiones, y asegura una larga vida útil. El sistema de PLASSON es una inversión excelente, tanto para las infraestructuras públicas de aguas residuales como para los sistemas privados.

Los sistemas de PLASSON para aguas residuales son muy duraderos y resistentes a las cargas axiales, gracias a la versatilidad de sus productos que pueden fusionarse completamente después de la instalación.

Wastewater Adjustable Saddle*

475804

Ramal Para Aguas Residuales*

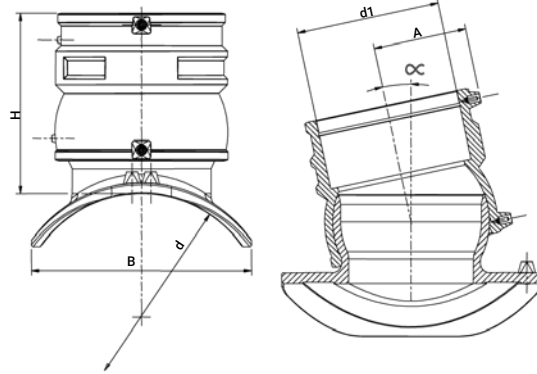

Product Code	Size d x d1	B	H	A	L	UC	W
475804200160	200 x 160	208	202	105	290	4	2050
475804250160	225-250 x 160	225	202	105	290	4	2060
475804315160	280-315 x 160	247	202	105	290	4	2070
475804560160	355-560 x 160	263	202	105	290	4	2080
475804710160	560-710 x 160	277	202	105	290	4	2100

* See dedicated tools at "specialized installation tools for Plasson products" section, page 183 | * Consulte las herramientas necesarias y específicas en la sección "Herramientas especiales para la instalación de productos Plasson", página 183.

Wastewater Saddle 45° - Inlet 110*

4758A4

Ramal 45° de Salida Para Aguas Residuales*

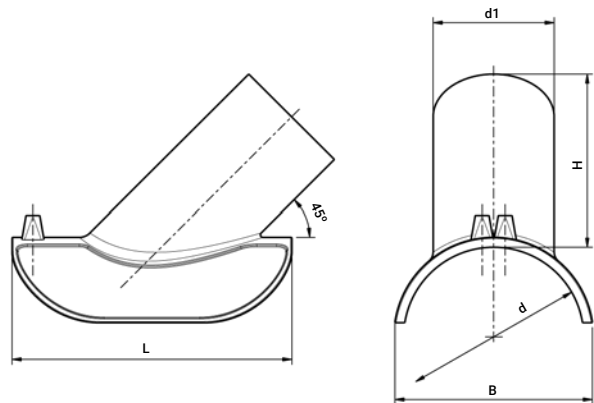

Product Code	Size d x d1	L	B	H	UC	W
4758A4160110	160-200 x 110	255	182	158	10	710
4758A4250110	225-315 x 110	255	221	158	10	656

* See dedicated tools at "specialized installation tools for Plasson products" section, page 183 | * Consulte las herramientas necesarias y específicas en la sección "Herramientas especiales para la instalación de productos Plasson", página 183.

Wastewater Saddle PVC/PP Adaptor Inlet*

4758V4

Collarín lightfit de transición para aguas residuales de PE A PP/PVC *

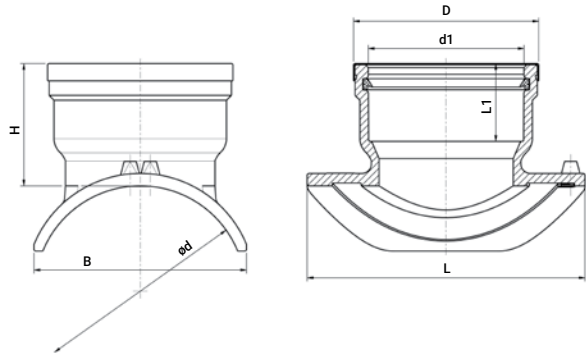

Product Code	Size d x d1	B	H	L	L1	D	UC	W
4758V4200160	200 x 160	208	125	290	80	190	6	1660
4758V4250160	225-250 x 160	225	125	290	80	190	6	1309
4758V4315160	280-315 x 160	245	125	290	80	190	6	1326
4758V4560160	355-560 x 160	263	125	290	80	190	6	1430
4758V4710160	560-710 x 160	277	125	290	80	190	6	1527

* See dedicated tools at "specialized installation tools for Plasson products" section, page 183 | * Consulte las herramientas necesarias y específicas en la sección "Herramientas especiales para la instalación de productos Plasson", página 183.

Wastewater Saddle Spigot Inlet*

4758S4

Collarín lightfit de transición para aguas residuales de PE /PE*

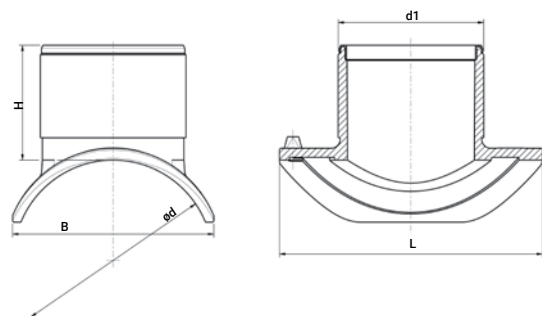

Product Code	Size d x d1	B	H	L	UC	W
4758S4200160	200 x 160	208	125	290	6	1091
4758S4250160	225 - 250 x 160	225	125	290	6	1239
4758S4315160	280 - 315 x 160	247	125	290	6	1260
4758S4560160	355 - 560 x 160	263	125	290	6	1300
4758S4710160	560 - 710 x 160	277	125	290	6	1310

* See dedicated tools at "specialized installation tools for Plasson products" section, page 183 | * Consulte las herramientas necesarias y específicas en la sección "Herramientas especiales para la instalación de productos Plasson", página 183.

Wastewater Adjustable Elbow One Sided

4747D4

Codo Ajustable Para Aguas Residuales

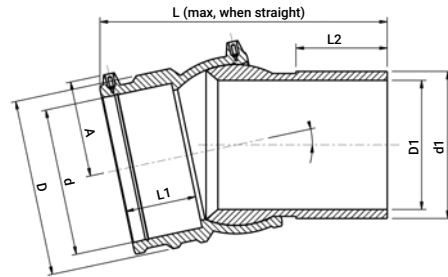

Product Code	size dxd1	SDR	D	D1	L	L1	L2	A	UC	W
4747D4160	160	17	193	141	298	78	98	105	6	3030

Wastewater Manhole Adaptor

37020/477207

Adaptador Para Pozo de Aguas Residuales

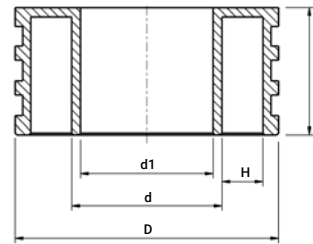

Product Code	Size d	L	d1	D	H	UC	W
37020110	110	135	97	216	37	—	1650
37020125	125	135	111	235	39	—	1800
37020140	140	135	123	254	39	—	1950
477207160	160	135	141	280	39	6	2524
37020180	180	135	157	335	66	4	3550
37020200	200	135	176	355	56	2	3660
477207225	225	135	198	355	44	2	3902
37020250	250	135	220	400	54	2	3740
477207280	280	135	247	400	39	2	5027
37020315	315	135	278	450	46	2	5130
37020355	355	135	313	500	50	2	6480
37020400	400	135	353	560	59	1	8260
37020450	450	135	397	592	50	—	22350
37020500	500	135	441	651	54	—	23600
37020560	560	135	494	705	51	—	34500
37020630	630	135	555	773	50	—	47370

Wastewater PE to PVC Adaptor

4701V4

Adaptador Para PE A PVC

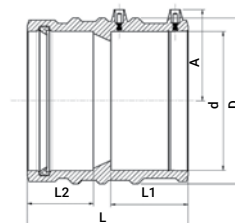

Product Code	Size d	L	L1	L2	D	A	UC	W
4701V4160	160	187	90	77	193	106	6	1546

Wastewater Adjustable Elbow PE to PVC

4747V4

Codo Ajustable de Transición de PE a PVC

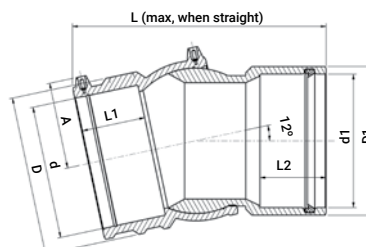

Product Code	Size d x d1	D	D1	L	L1	L2	A	UC	W
4747V4160	160 x 160	193	180	253	78	80	105	6	2140

Wastewater Elbow 45°

470604

Codo 45° Para Aguas Residuales

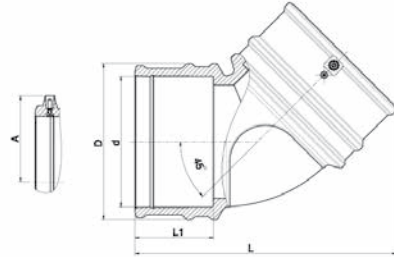

Product Code	Size d	L	L1	D	A	UC	W
470604160	160	325	98	193	106	4	2000

Wastewater Elbow 30°

473304

Codo 30° Para Aguas Residuales

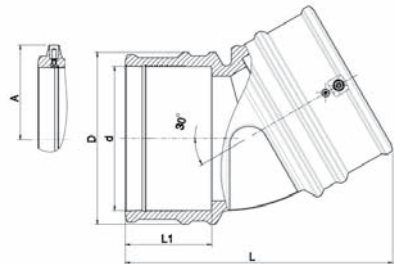

Product Code	Size d	L	L1	D	A	UC	W
473304160	160	302	98	193	106	5	1850

Wastewater Elbow 15°

473704

Codo 15° Para Aguas Residuales

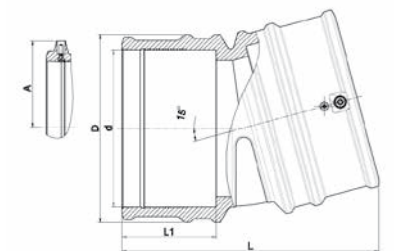

Product Code	Size d	L	L1	D	A	UC	W
473704160	160	267	98	193	106	5	1740

Technical Specifications for PLASSON Electrofusion Fittings

Fitting Pressure Rating and Pipe Compatibility

PLASSON Fittings are weldable to PE80, PE100, PE100-RC and PE-X pipes (most fittings)*.

Check that the pipe SDR is compatible with the PLASSON fittings. The range of compatible pipe SDR's for each specific fitting is defined on the fitting barcode label.

For questions regarding pipe SDR compatibility refer to PLASSON literature or contact your local PLASSON representative.

* Please consult your PLASSON representative

The following is a general guideline for PLASSON EF product pipe SDR compatibility (in any case of discrepancy between the figure below and the figure on the barcode label, always refer to the barcode data).

PLASSON's Electrofusion Fittings:

- PN 16 (Water)
- PE100 SDR11 (Gas)
- Up to 75mm (inclusive) are Weldable to Pipes SDR ≤ 11
- Elbows and Tees of main diameter 40mm-75mm ≤ 17
- 90mm & Up are Weldable to Pipes SDR ≤ 17
- 63-75mm Tapping Saddles and Valves are suitable for SDR11

Note: for tapping SDR ≤ 11 pipes (size 63 and up), please consult your PLASSON representative.

LightFit:

- PN 10 (Water)
- PE100 SDR17 (Gas)
- 40mm - 75mm are Weldable to Pipes SDR ≤ 17
- 90mm are Weldable to Pipes SDR ≤ 26
- 110mm - 710mm are Weldable to Pipes SDR ≤ 33
- 800mm and up are weldable to pipes SDR≤41

Wastewater Saddle

- PN 0.5 (Water)
- 200mm & Up are Weldable to Pipes SDR ≤ 26

Wastewater Adjustable Elbow

- PN 0.5 (Water)
- 160mm is Weldable to Pipes SDR ≤ 17

Measure the pipe external diameter toward the pipe end using a Pi tape. The pipe external diameter must be within the tolerances defined in International standards such as ISO 4437-2, AS/NZS, 4130, EN 1555-2 and EN 12201-2.

Material

All PLASSON electrofusion fittings are produced from material class PE100 which conform to international standards for potable water and natural or suitable manufactured gas systems.

Standards

PLASSON electrofusion fittings are designed, tested and quality controlled according to PLASSON's internal standards. These standards are based on the following international standards:

- EN 1555
- EN 12201
- NF 136
- AS/NZS 4129
- WIS 4-32-14
- WIS 4-32-15

Quality

PLASSON has incorporated a quality assurance system in accordance with ISO 9001. Operating approval according to ISO 9001 was granted to PLASSON by the Israeli Standard Institute. Operating according to the ISO 9001 quality assurance system imposes stringent standards of control throughout the manufacturing processes.

Abbreviations used on the product description pages of this catalog:

A, A1	Height of shroud from centerline	L, L1, L2	Length
d, d1	Nominal diameter of fitting or outlet	c	Number of bolt holes in flanges
D, D1	Diameter	s	Diameter of bolt holes in flanges
DN	Nominal bore corresponding approximately to the inside diameter of the pipe	t	Thickness of metal flange
Dp	Pitch circle diameter of bolt holes in flanges	W	Weight in grams
G, R, Rp	Threaded outlet diameter	UC	Units per carton
H	Height	Fusion and cooling time are specified on the individual product.	

Whereas the products shown in this catalogue illustrate and describe the current state of their development, PLASSON reserves the right at all times to make such technical alterations as it shall see fit to its products. Although every care has been taken in the preparation of the information, specifications and other data included in this catalogue, we cannot rule out inadvertent errors or omissions. Purchasers should take into account possible deviations or variations which will not substantially diminish the functionality or performance of the products, and, in many cases, are designed to improve the same.

PLASSON® is the Registered Trademark of PLASSON Ltd. or PLASSON Maagan Michael Industries Ltd. PLASSON's products are protected by patents, trademark, design and copyright laws.

Especificaciones técnicas para los accesorios ElectroFusión de PLASSON

Presiones nominales y compatibilidad con la tubería

Los accesorios electrofusión de PLASSON se pueden soldar a tuberías de materiales PE80, PE100, PE100-RC, PE-X (la mayoría de los accesorios)*

Por favor revise que el SDR de la tubería es compatible con el rango declarado en el código de barras del accesorio PLASSON. Cada accesorio PLASSON contiene esta información.

Nota: para obtener más información sobre SDR de tuberías vea la información del fabricante de la tubería a soldar y literatura de PLASSON. Ante cualquier duda consulte a su representante de PLASSON

A continuación una guía general sobre la compatibilidad de accesorios PLASSON según el SDR del tubo a electrofundar. (En caso de existir alguna discrepancia por favor proceda según indica la calcomanía del accesorio que contiene el código de barras).

Presiones nominales

Las presiones nominales de todos los accesorios electrofusión de PLASSON son las siguientes:

- PN 16 (Agua)
- MOP10 (Gas)

Accesorios de ElectroFusión de PLASSON

- Hasta 75mm (inclusive), soldables en tuberías SDR ≤ 11
- Codos y Tes en diámetros 40mm – 75mm ≤ 17
- De 90mm en adelante soldables en tuberías SDR ≤ 11
- De 63-75mm Tomas en carga y Válvulas soldables en tuberías SDR 11

NOTA: Para tuberías SDR ≤ 11 (diámetro desde 63mm hacia arriba) consulte a su representante de PLASSON.

LightFit:

- PN10 (Agua)
- PE100 SDR 17 (GAS)
- 40mm - 75mm soldables en tuberías SDR ≤ 17
- 90mm soldables en tuberías SDR ≤ 26
- 110mm - 800mm soldables en tuberías SDR ≤ 33

Ramales de ElectroFusión PLASSON para aguas residuales

- PN 0.5 (Agua)
- De 200mm en adelante en tuberías SDR ≤ 26

Codos ajustables de ElectroFusión para aguas residuales

- PN 0.5 (Agua)
- De 160mm en adelante en tuberías SDR ≤ 17

Para medir el diámetro externo de una tubería utilice una cinta PI. El diámetro externo debe estar contemplado dentro de las tolerancias estipuladas en las normas internacionales ISO 4437-2, AS/NZS.

Material

Todos los accesorios ElectroFusión de PLASSON se fabrican con material de clase PE100, de conformidad con las normas internacionales para sistemas de agua potable y gas natural o procesado. Accesorios de PE80, disponibles a petición del cliente.

Normativa

El diseño, las pruebas y el control de calidad de los accesorios electrofusión de PLASSON se llevan a cabo de acuerdo con las normas internas de PLASSON, basadas en las siguientes normativas internacionales:

- EN 1555
- EN 12201
- NF 136
- AS/NZS 4129
- WIS 4-32-14
- WIS 4-32-15

Aseguramiento de Calidad

PLASSON utiliza el sistema de aseguramiento de calidad conforme a la normativa ISO 9001. La certificación de la empresa de acuerdo con ISO 9001 le fue otorgada a PLASSON por el Instituto Israelí de Normas Industriales. La operación conforme a la normativa de aseguramiento de calidad ISO 9001 impone estrictos procedimientos de control durante todos los procesos de fabricación.

Abreviaturas utilizadas en la descripción de productos de este catálogo:

A, A1	Altura desde la línea central a la cubierta del resistor	L, L1, L2	Longitud
d, d1	Diámetro nominal del accesorio o salida	c	Número de orificios en las bridas
D, D1	Diámetro	s	Diámetro de los orificios p/tornillos en las bridas
DN	Diámetro nominal interno, correspondiente aproximadamente al diámetro interno del tubo	t	Grosor de la brida metálica
Dp	Diámetro de los orificios en las bridas	W	Peso en gramos
G, R, Rp	Diámetro de la salida roscada	UC	Cantidad por caja de cartón
H	Altura	Los tiempos de soldadura y enfriamiento se indican en cada producto.	

Si bien en este catálogo se ilustran y describen los productos en el estado actual de su desarrollo, PLASSON se reserva el derecho de introducir en cualquier momento las modificaciones técnicas que considere convenientes.

La preparación de la información, especificaciones y otros datos se ha hecho con el mayor cuidado, no obstante lo cual no podemos asegurar que estén libres de errores u omisiones involuntarios. El cliente debe tener en cuenta la posibilidad de desviaciones o variaciones que no afectarán significativamente el funcionamiento o rendimiento de los productos y que, en muchos casos, están destinadas a mejorarlos.

PLASSON™ es la marca registrada de PLASSON Ltd. o PLASSON Maagan Michael Industries Ltd.

Los productos de PLASSON están protegidos por derechos de patente, marcas comerciales, diseño y leyes de copyright.



PLASSON

ELECTROFUSION TOOLING

Milder

— VEELZIJDIG IN LEIDINGSYSTEMEN —

Content

Electrofusion Tooling - Herramientas Para Electrofusión

Pipe Preparation - Preparación de la tubería	168
What is PLASSON SMARTFUSE? - Que es PLASSON SMARTFUSE	170
Control Boxes - Controladores Electrofusión	171
Control Boxes Cont. - Características	173
Electrofusion Control Boxes & Accessories - Accesorios para controladores Electrofusión	176
Pipe Cutting - Cortadores de tuberías	177
Pipe Peeling - Rascadores de tuberías	178
Rerounding Tools - Redondeadores	180
Squeeze Off Tools - Prensas / Obturadores	181
Pipe Cleaning - Limpiadores de tubería	182
Pipe Clamping - Sujetadores	182
Specialized Installation Tooling For PLASSON Products - Sujetadores para la instalación de productos PLASSON	183
Large Bore Saddles Installation Tools - Sujetadores para la instalación de tomas simples/bridadas de gran diámetro / Ramales PLASSON	184
Tools for Drilling - Herramientas para perforación de tomas simples/bridadas de gran diámetro / Ramales PLASSON	186
Hot Tapping Tools - Herramientas para tomas en carga de grandes diámetros	187



PF-Schweißtechnologie GmbH (PFS)

PLASSON'S range of electrofusion tooling is designed and manufactured by our joint venture partner, PFS. Founded in 1997 in Germany, PFS quickly developed into one of the world's leading manufacturers of plastic welding technologies for pipeline construction. The product range includes a wide variety of electrofusion control units, butt fusion machines, extensive accessories and a complete portfolio of tools for the preparation of plastic pipes for welding.



High Quality Products

Thousands of customers around the globe rely on the high quality of PFS products.

Product development is conducted by employees with many years of experience, know-how, dedication and with a high capacity to innovate.

Close cooperation with end users of PFS products and systems provides real field feedback to allow refinement of products, even at component level, resulting in products robust enough to handle even the most difficult site conditions.



Turn your PLASSON Control Box into the ultimate welding machine with our **new Smartphone App**.



Available now

Features of the Free Upgrade

- ✓ **Smartphone control** of your box, with no mobile network coverage needed
- ✓ **Improved quality control** with guided welding process and photo capture of crucial steps (kept with the weld record)
- ✓ **Data recording** including physical location of each weld
- ✓ Ability to **identify installer** of each weld
- ✓ Ability to **weld all fittings***



Smarter plumbing
with PLASSON.



*Monomatic Control Boxes will be limited to emergency welds of other fittings



Pipe Preparation | Preparación de la tubería

Pipe preparation is the basis of the electrofusion process.

The pipe preparation includes few simple yet important steps described below:

Cutting of the pipe:

The pipe ends must be cut square and even.

Various approved pipe cutting tools



1. Rotational pipe cutter



2. Pipe cutter

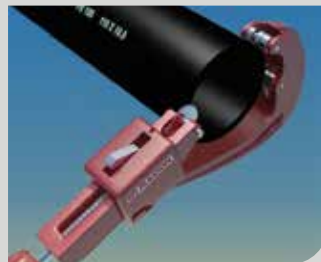

3. Rotational pipe cutter (S-type)

Marking and scraping:

In order to achieve a good weld the oxide layer of the pipe must first be removed.

Mechanical peeling tools are strongly preferred, as they achieve a consistent pipe surface preparation

Hand scraper

When using hand scrapers - perform long even scrapes starting from outside the marked areas to avoid "cratering" in the fusion zone of the fitting until all marks are removed.

Rotational scraper

One scraping pass is to be carried out in order to remove approx. 0.2 to 0.3 mm of the outer pipe surface. If the pipe diameter is still too large, additional scraping may be performed in order to facilitate insertion, as long as the average pipe diameter is kept above minimum.

This is the preferred peeling method as it will remove the pipe surface evenly.

Rotational Scraper / Hand scraper

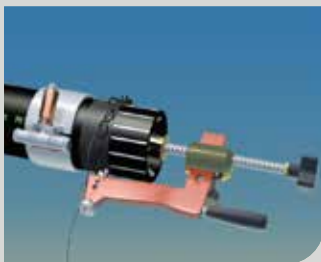

1. Rotational scraper



2. Hand scraper



3. Do not touch the scraped area with bare hands after scraping and cleaning

Pipe rounding:

Electrofusion fittings are designed to work on a round pipe.
Do not perform an electrofusion weld if the pipe does not meet the criteria defined below at the section where the EF fitting is to be welded.
Use a pipe re-rounder if necessary to correct pipe ovality.

For pipe DN < 315

$d1 - d2 < 1.5\% \text{ DN}$ or $< 3\text{mm}$ (whichever is the smallest value.)

For pipe DN \geq 315

$d1 - d2 < 1\% \text{ DN}$ or $< 5\text{mm}$ (whichever is the smallest value.)

It is extremely important to re-round the pipe

prior to the welding process.

In order to do so, measure the pipe diameter with a suitable measuring tool to find the maximum and minimum diameter points and calculate the difference between these diameters.

Pipe ovality (out of roundness) = $d1 - d2$

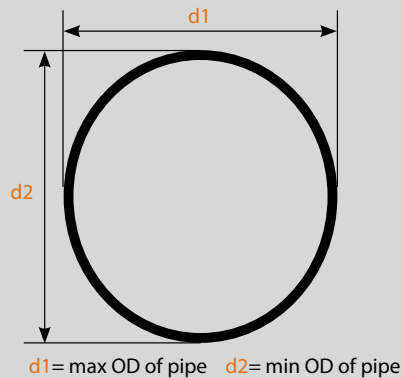

Clamping and alignment (fitting restraint):

Pipe movement during welding and cooling cycles might occur as well as sources of stress and strain that can be applied on the pipe/fitting assembly.

All electrofusion socket fittings (regardless of the manufacturer) must be clamped to the pipes in order to eliminate all mechanical stress in the welding zone.

Example of clamping and alignment device



1. Misaligned pipes



2. Example of clamping and alignment device

PLASSON SmartFuse Electrofusion System

What Is PLASSON SmartFuse?

SmartFuse is PLASSON's smart welding recognition system. By using a compatible PFS electrofusion controller, this system enables a simple identification of the electrofusion fittings to be welded and their welding time. Connecting the controller red cable to the red terminal pin initiates the identification. The controller reads the value of the resistor located in the red terminal pin and allocates the nominated welding time. All that is left for the operator to do is compare the welding time shown on the controller screen to that on the barcode label and press the "start" button on the controller to start the welding process! Simple, safe and reliable.

How Is This Done?

PLASSON electrofusion fittings are designed in a way that enables a single weld time in an ambient temperature range of -10°C up to +45°C. The weld energy will adjust "automatically" as function of the ambient temperature due to the metal coil electrical resistance which will change. At lower temperatures the coil resistance will decrease, resulting in higher energy applied to the weld, while at higher temperatures the energy will decrease.

No Temperature Compensation

Other fittings in the market compensate for the change in ambient temperature by changing the welding time, a system called temperature compensation. Temperature compensation is achieved by a specially defined barcode label, which instructs the welding controller to increase or decrease the weld time as function of the ambient temperature measured by the controller. Such system relies on the legibility of the barcode, and an assumption that the temperature at the point at which it is read is identical to that at the pipe/fitting interface, which is not always the case. If the weld is performed without a barcode reading EF controller, the operator will need to estimate the temperature on site, read the temperature compensation tables correctly (if supplied and legible) and enter the new weld time into the controller. Such process relies on operator skill/judgment and as such, is open to human error.

Electrofusion Control Unit

PF control boxes dynamically monitor the weld process when used with PLASSON ElectroFusion fittings.

- Dynamic monitoring - By continually monitoring the weld current, an electrofusion Control Unit will shut down if the current increases above the dynamic tolerance range, thereby avoiding the overheating and anti-oxidant depletion of PE materials which can adversely affect long-term weld integrity.
- Generator variability tolerance - PF control boxes are tolerant to generator variability as they accept a large voltage range and frequency variation.
- Numerous servicing centres for PF welding equipment are available.

What can go wrong?

Without dynamic monitoring of a PLASSON Automatic Welding electrofusion Control Unit, faults may occur unnoticed during the weld process causing the fitting to fail once in general use. Common causes of this can be seen in the diagram below.

Typical Electrofusion Welding Faults

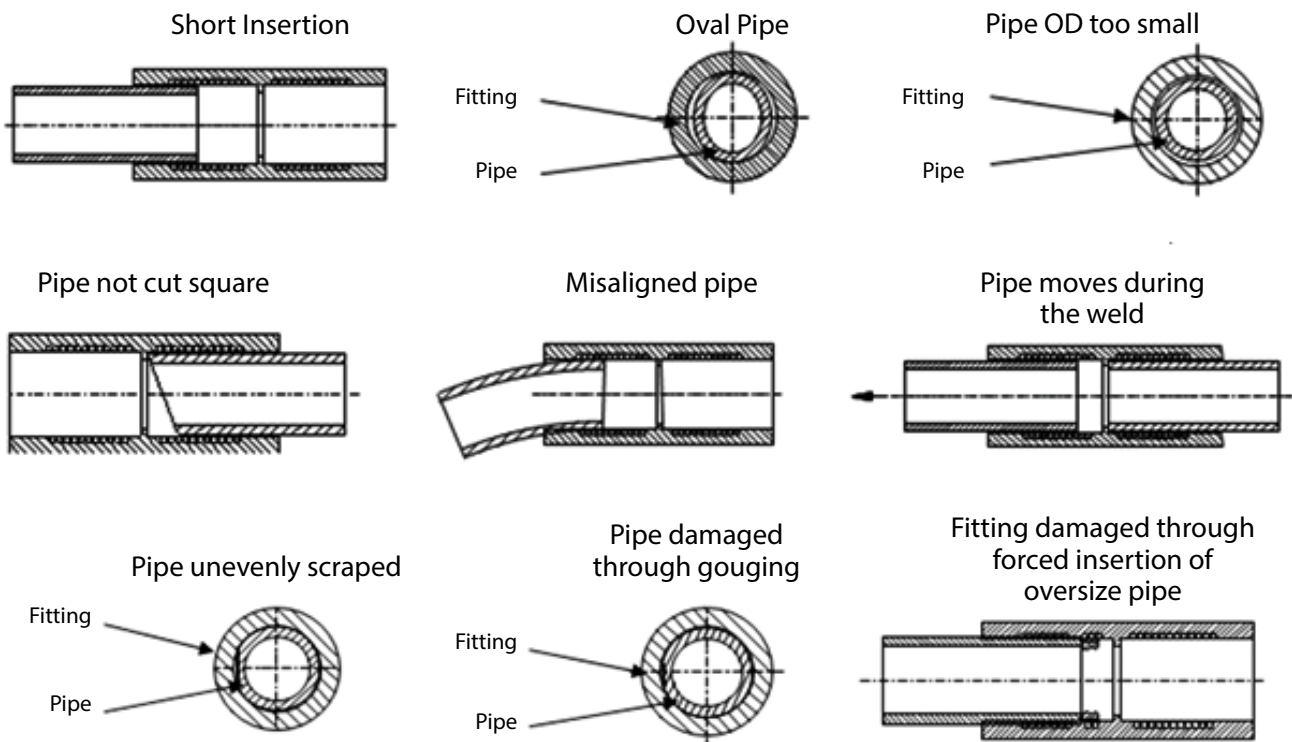

Please note:

PLASSON Automatic electrofusion Control Unit will not carry out this dynamic monitoring process on other manufacturers' fittings.



POLYCODE

PolyCode 180 **New PolyCode 400**

- ✓ Welds PLASSON fittings
- ✓ Light
- ✓ Compact
- ✓ Bluetooth enabled for smartphones using PLASSON SmartFuse App
- ✓ Use App to automatically determine and record welding parameters
- ✓ Tough weather-proof carry case



Control Boxes | Controladores Electrofusión

Control Box Comparison Table

Features	POLYCODE	SmartFuse	Polymatic Plus	PF PolyControl Plus V2.0
Fitting size	180mm/400mm	up to 355mm	up to 800mm (sizes above 355mm require cooling between welds)	Any size, continuous welding, no cooling
Welds	Any EF fittings	PLASSON only (competitor allowance with App)	Any EF fittings	Any EF fittings
Weld Tip Size	4.0mm Universal	4.0mm Universal	4.0mm Universal	4.0mm Universal
Bluetooth	Y	Y	Y	Y
PLASSON SmartFuse Mode (Automatic)	Y	Y	Y	Y
Manual Input of Welding Time	N	N	Y	Y
Welding Voltage	8-48 V	39.5V	8-48V	8-48V
Output Current (Maximum)	75A (54A)	60A (80A)	80A (110)A	90A (105A)
Data recording	Y	Y with app	Y	Y
Multilingual Display Messages	Y	Y	Y	Y
Error messages in plain text	Y	Y	Y	Y
Adjustable display contrast	Y	Y	Y	Y
Dynamic process supervision	Y	Y	Y	Y
Auto software check	Y	Y	Y	Y
Resistance check	Y	Y	Y	Y
Ramped start	Y	Y	Y	Y
Service Message	After 200 Hours or 12 Months	After 200 Hours or 12 Months	After 200 Hours or 12 Months	After 200 Hours or 12 Months
Barcode reading capability	Y with app	Y with app	Y	Y
Fitting and Operator traceability	Y with app	Y with app	Y	Y
Earth Pin	10A	15A	15A	15A
Active Cooling	N	N	N	Y

The electrofusion control units made by PF Schweißtechnologie GmbH provide the following features to increase the generator suitability:

- High tolerance for the input voltage
 - 190V to 300V at 230V nominal
 - 90V to 150V at 110V nominal
- High tolerance for the input frequency
 - 40Hz to 70Hz
- Display of current input voltage and frequency.
- Soft-Start for limitation of the generator load.

Despite these characteristics, the used generators must meet the following requirements and recommendations, in order to avoid damage to the electrofusion control unit.

This ensures that the internal monitoring functions of the control unit do not interrupt the welding process:

- Suitable for phase-angle control
- 230 V
 - No-load voltage adjustable between 240 V and 260 V
 - Output current of 18 A on one phase
 - For PolyControl: Better 21 A on one phase
- 110 V
 - No-load voltage adjustable between 120 V and 130 V
 - Output current of 36 A on one phase
- Stable output voltage and engine RPM even with rapidly changing load
- Synchronous generators with mechanical RPM control preferred
- Voltage peaks must not exceed 800 V



Extension lines

When using extension cables, it is essential that you also observe the information on the required conductor cross-sections and the maximum length. If you use cable drums, you must unwind them completely.

Control Boxes Cont. | Características

SmartFuse



Attention!

For welding of couplers in with a welding time of 900 s a stable and continuous supply voltage of 230 V is mandatory. When using a generator, it must be set to a no load voltage of between 240 V and 260 V.

The electrofusion control units of type Monomatic, Monomatic (Bluetooth), Monomatic Data USB and Monomatic Data USB (Bluetooth) can only be used together with SmartFuse-capable fittings and couplers. Only couplers that have a welding time of 900 s or below can be welded.

Welding time of the fittings	Recommended generator output power
20 to 600 s	3.2 kW
750 to 900 s	4.5 kW (mechanically controlled) 5.0 kW (electronically controlled)
> 900 s	Not possible to weld
Extension cord	Conductor cross-section
Up to 30 m	3 × 1.5 mm ²
Up to 50 m	3 × 2.5 mm ² (for the entire length)



Polymatic Plus

Variants: All

Usage for dimensions from **20 to 630 mm** without limitation.

When working with dimensions from 630 mm on, longer cool-down times must be provided for because otherwise the device might show the "Device too hot" error message. In this case, it is necessary to let the electrofusion control unit cool down before putting it to use again.

Dimension range of fittings	Recommended generator output power
20 to 160 mm	3.2 kW
180 to 500 mm	4.5 kW (mechanically controlled) 5.0 kW (electronically controlled)
> 500 mm	6.5 kW (mechanically controlled) 7.5 kW (electronically controlled)
Extension cord	Conductor cross-section
Up to 30 m	3 × 1.5 mm ²
Up to 50 m	3 × 2.5 mm ² (for the entire length)



Control Boxes Cont. | Características

PolyControl Plus V2.0 BT

Variants: All

Suitable without restriction for all coupler dimensions resp. PKS-systems that have a maximum continuous current consumption of **up to 85 A.**

Dimension range of fittings	Recommended generator output power
20 to 160 mm	3.2 kW
180 to 500 mm	4.5 kW (mechanically controlled) 5.0 kW (electronically controlled)
> 500 mm	6.5 kW (mechanically controlled) 7.5 kW (electronically controlled)
Extension cord	Conductor cross-section
Up to 30 m	3 × 2.5 mm ²
Up to 50 m	3 × 4.0 mm ² (for the entire length)



PolyCode 180 mm / 400 mm

Variants: All



Attention!

For welding of couplers in 180 mm a stable and continuous supply voltage of 230 V is mandatory. When using a generator, it must be set to a no load voltage of between 240 V and 260 V.

PolyCode 180 mm

Dimension of coupler	Requirements
16-140° mm	Usable without additional restrictions.
160-180° mm	Longer cool-down times must be provided because otherwise, the device might show the "Device too hot" error message. In this case, it is necessary to let the electrofusion control unit cool down before putting it to use again.
180° mm (SmartFuse)	Only couplers that have welding time of 400sec or below.
Saddle (Barcode)	Saddle with a heating coil resistance of >1°Ω and a welding time below 1300sec.
180° mm (Barcode)	Only couplers that have a resistance of >0.6°Ω
>180° mm	Couplers >180°mm cannot be welded.

PolyCode 400 mm

Dimension of coupler	Requirements
16-400° mm	Usable without additional restrictions.
>400° mm	When working with dimensions from 400°mm and up, longer cool-down times must be provided because otherwise, the device might show the "Device too hot" error message. In this case, it is necessary to let the electrofusion control unit cool down before putting it to use again.

Before processing fittings in this dimension range, you have to check that the welding current demand of the fitting does not continuously exceed the output current of the device and that the maximum output current is not exceeded.

Dimension range of fittings	Recommended generator output power
20 to 75 mm	2 kW
90 mm and above	4 kW
Extension cord	Conductor cross-section
Up to 50 m	3 × 1.5 mm ²



Electrofusion Control Boxes & Accessories | Accesorios para controladores Electrofusión

POLYCODE	3m Fixed lead
SMARTFUSE	5m Lead
Polymatic Plus	5m Lead
PolyControl Plus V2	5m Lead



Welding Cables for SmartFuse or Digimatic Universal	Code
5m Detachable Lead with universal terminals	29142.0610.032
10m Detachable Lead with universal terminals	29142.0611.005



Welding Cables for Polymatic Plus USB with Universal (Reading Pen Sold Separately)	Code
5m Detachable Lead with 4.0 mm terminals	29142.0610.014
10m Detachable Lead with 4.0 mm terminals	29142.0611.016/1

Smartfuse Adaptors - 29142.0200.006



Reading Pens	Code
Reading Pen 2DL	29142.0100.001
Barcode Scanner Touch ID	29142.0120.004
Barcode Scanner Touch ID for PolyCode	29142.0120.003

Transport Case	Code
Transport Case (Monomatic/ Digimatic/ Polymatic Plus)	29141.2800.005

Ruling and Marking	Code
Magnetic Circular Pipe Ruler	29144.4402.001
Pi-Meter 20-700mm with Vernier 0.1mm	29145.5003.001
Pi-Meter 20-1200mm with Vernier 0.1mm	29145.5003.000

Marking Pens	Code
Marking pens broad white	29145.3100.019



Pipe Cutting | Cortadores de tuberías

Secateur Pipe Cutter	Code
Pipe Cutter up to 63mm (Single Hand)	29145.3000.007
Pipe Cutter Spare Blade for 63mm (Single Hand)	29145.3000.008
Pipe Cutter up to 63mm (Two Hand Use)	29145.3000.001

Rotational Pipe Cutter (S-Type)	Code
Rotational Pipe Cutter - 20 - 75mm	29145.3001.004
Rotational Pipe Cutter Spare Blade 20-75mm	29145.3001.005
Rotational Pipe Cutter 50 - 140mm	29145.3001.001
Rotational Pipe Cutter 90 - 160mm	29145.3001.002
Spare Blade 140 / 160mm	29145.3001.003

Rotational Pipe Cutter	Code
Rotational Pipe Cutter 32-125mm	29144.4400.006 ■
Rotational Pipe Cutter 90-315mm	29144.4400.005 ■
Rotational Pipe Cutter 63-225m	29144.4400.004 ■

Rotary Circular Saws 230 V	Code
250-500mm (Max. Cutting Depth 65mm)	29144.4401.002 ■
500-1200mm (Max. Cutting Depth 85mm)	29144.4401.001 ■
180-400 mm (Max. Cutting Depth 38mm)	29144.4401.005 ■



Pipe Peeling | Rascadores de tuberías

Hand Scraper	Code
Hand Scraper - Small 1 1/2"	29145.3002.001
Blades for Small Hand Scraper (2)	29145.3002.002
Hand Scraper - Large 2 1/2"	29145.3002.003
Blades for Large Hand Scraper (2)	29145.3002.004



Rotational Peeling Tool Peeling for Saddle and Coupler Installation	Code
Rotational Peeling Tool 16-40mm	29144.4200.000/1
Rotational Peeling Tool 20-63mm	29144.4200.001
Rotational Peeling Tool 20-125mm	29144.4200.031
Rotational Peeling Tool 90-315mm	29144.4200.033
Rotational Peeling Tool 63-225mm	29144.4200.032



U-Peeler Peeling for Saddle and Coupler Installation	Code
U-Peeler 63mm	29144.4800.063
U-Peeler 75mm	29144.4800.075
U-Peeler 90mm	29144.4800.090
U-Peeler 110mm	29144.4800.110
U-Peeler 125mm	29144.4800.125
U-Peeler 140mm	29144.4800.140
U-Peeler 160mm	29144.4800.160
U-Peeler 180mm	29144.4800.180
U-Peeler 200mm	29144.4800.200
U-Peeler 225mm	29144.4800.225
U-Peeler 250mm	29144.4800.250
U-Peeler 280mm	29144.4800.280
U-Peeler 315mm	29144.4800.315



Pipe End Scraper Tool	Code
Pipe End Scraper Tool 63-200mm	29144.4200.015
Pipe End Scraper Tool 90-315mm	29144.4200.027
Pipe End Scraper Tool 180-400mm	29144.4200.016
Pipe End Scraper tool 90-315mm (PE-X) with rails	29144.4200.027/1
Pipe End Scraper tool 180-400mm (PE-X) with rails	29144.4200.016/1



Pipe End Peeler	Code
Pipe End Peeler 450-1000mm	29144.4200.300
Pipe End Peeler 450-1000mm 230V	29144.4200.301
Pipe End Peeler 450-1000mm 110V	29144.4200.302



Mechanical Rotational End Peeler Tool Battery Powered	Code
PLASSON Scraper Tool For Pipe Ends 20-75mm Incl. Cordless Drill BOSCH in Plastic Suitcase	29144.4200S101



Chain Peelers Peeling for Saddle and Coupler Installation	Code
Chain Peeler 110-400mm	29144.4200.013 ■
Chain Peeler 250-450mm	29144.4200.007 ■
Chain Peeler 250-800mm	29144.4200.009
Extension 900-1000mm for Rotational	29144.4200.010
Chain Peeler 400-800mm 230 V	29144.4200.036 ■
Extension 900-1000mm for Electrical Chain Peeler	29144.4200.038 ■
Chain Peeler 800-1200mm 230 V	29144.4200.037
Extension 1400-1600mm for Electrical Chain Peeler	29144.4200.039

Powered Scrapers	Code
Electrical Saddle Scraper (110V)	29144.4200.025 ■
Electrical Saddle Scraper (230V)	29144.4200.024 ■
Electrical Saddle Scraper Cordless (230V)	29144.4200.026



Battery Powered Chain Peeler

- ✓ Reduce pipe peeling time by almost 75%
- ✓ A new battery powered solution for the fast, more efficient and reliable preparation of large bore PE pipe for electrofusion welding.
- ✓ For use on 400-800mm pipe, with an optional extension kit to 1000mm, the PLASSON replaces hand powered tools to remove the oxidised and contaminated outer layer on PE pipe by peeling a consistent 0.2-0.3mm layer from the pipe surface. A version for pipe 800-1200mm is also available. It can be extended to 1600 mm by the optional extension kit.
- ✓ The chain peeler is designed to work with challenges of ovality, flatness and varying pipe wall thickness, resulting in very large reductions in coupler handling times.
- ✓ Supplied with two quick charge batteries.



Rerounding Tools | Redondeadores | Two required - one rounding tool for each side of fitting.

Rerounding Shell 32-63mm	Code
32-40mm	29144.4602.006
50-63mm	29144.4602.007

Rounding Clamp 63-400mm	Code
63-180mm	29144.4602.005
110-250mm	29144.4602.003
180-315mm	29144.4602.004
250-400mm	29144.4602.009

Rounding Pliers	Code
32-40mm	29144.4602.016
50-63mm	29144.4602.015

Rounding Rings 63-250mm	Code
63mm	29145.3006.063
75mm	29145.3006.075
90mm	29145.3006.090
110mm	29145.3006.110
125mm	29145.3006.125
140mm	29145.3006.140
160mm	29145.3006.160
180mm	29145.3006.180
200mm	29145.3006.200
225mm	29145.3006.225
250mm	29145.3006.251

Hydraulic Rounding Shell 315-400mm	Code
Hydraulic Jack (315-400)	29145.3008.013
Rounding Shell 315mm (without jack)	29145.3008.001
Rounding Shell 355mm (without jack)	29145.3008.002
Rounding Shell 400mm (without jack)	29145.3008.003

Hydraulic Rounding Shell 450-630mm	Code
Hydraulic Jack (450-630)	29145.3008.014
Rounding Shell 450mm (without jack)	29145.3008.004
Rounding Shell 500mm (without jack)	29145.3008.005
Rounding Shell 560mm (without jack)	29145.3008.006
Rounding Shell 630mm (without jack)	29145.3008.007

Hydraulic Rounding Shell 710-900mm	Code
Hydraulic Jack (710-900)	29145.3008.015
Rounding Shell 710mm (without jack)	29145.3008.008
Rounding Shell 800mm (without jack)	29145.3008.009
Rounding Shell 900mm (without jack)	29145.3008.010

Hydraulic Strap Rounder	Code
450-710mm	29144.4602.017
Extension 800-1200mm	29144.4602.018
450-1200mm	29144.4602.019

* Hydraulic Tool. Use with PE pipes 450-800mm (Max. SDR 11)

EN259 Rounding Tool 450-1000mm	Code
450-1000mm	29144.4602.011



Rerounding Shell 315-900mm



Mechanical Rounding Tool 450-1000mm

Rerounding Tools Cont.

Rerounding Shell 63-225mm	Code
Used to round pipe after squeezing	
63mm	29145.3005.063 ■
75mm	29145.3005.075 ■
90mm	29145.3005.090 ■
110mm	29145.3005.110 ■
125mm	29145.3005.125
140mm	29145.3005.140
160mm	29145.3005.160
180mm	29145.3005.180
200mm	29145.3005.200
225mm	29145.3005.225



Squeeze Off Tools | Prensas / Obturadores

Manual Squeeze Off Tool For Gas Pipes	Code
16-32mm (wall 3mm) and 40mm SDR11	29144.4100.013 ■
Manual Squeeze Off Tool	Code
20-63mm Suits SDR11 16/20,25,32,40,50,63mm & SDR17 63mm Squeeze off is affected by turning the handle in a clockwise direction. Hydraulic operation. Metric limit plates set at 1.6t. Safety stops to prevent creep. Springs return jack to park position after squeeze off. Integral safety valve.	29144.4100.010 ■
Hydraulic Squeeze Off Tool	Code
63-90mm Sizes: 63,75,90mm. Hydraulic operation. Metric limit plates set at 1.6t. Safety stops to prevent creep. Springs return jack to park position after squeeze off. Integral safety valve.	29144.4100.006
63-180mm Suits 63-180mm SDR 11 & 17. Sizes: 63,75,90,110,125,160,180mm.	29144.4100.005 ■
63-200mm (Excl. 140mm) Suits 63-200mm SDR 11 & 17 (incl. 2 complete stopper sets). Sizes: 63,75,90,110,125,160,180 and 200mm. Hydraulic operation. Metric limit plates set at 1.6t. Safety stops to prevent creep.	29144.4100.011
75-200mm Suits 75-200mm SDR 11 & 17. Sizes:75,90,110,125,160,180 and 200mm. Hydraulic operation. Metric limit plates set at 1.6t. Safety stops to prevent creep. Springs return jack to park position after squeeze off. Integral safety valve. Springs return jack to park position after squeeze off. Integral safety valve.	29144.4100.007 ■



Pipe Cleaning | Limpiadores de tubería

Cleaning Pads	Code
Tangit Detergent, 1 Liter	29145.2000.001
100 cleaning pads with tangit	29145.2000.002

PLASSON Pipewipes ensure surfaces are clean before electrofusion jointing (scraping of pipe surface is still required). 120 sheets per canister.



Pipe Clamping | Sujetadores

Alignment Clamps	Code
<p>Pipe Clamp 16-63mm Adjustable to suit couplers, reducers, 22.5° 45° & 90° elbows and tees. Promotes restraint during the electrofusion process. Infinitely variable grip clamps to suit any combination of sizes, 16-63mm. Quick tightening operation, lightweight & easy to use.</p>	29144.4300.000
<p>Pipe Clamp 32-110mm Adjustable to suit couplers, reducers, 22.5° 45° & 90° elbows and tees. Promotes restraint during the electrofusion process. Infinitely variable grip clamps to suit any combination of sizes, 32-110mm. Quick tightening operation, lightweight & easy to use.</p>	29144.4300.001
<p>Pipe Clamp 63-225mm Adjustable to suit couplers, reducers, 22.5° 45° & 90° elbows and tees. Promotes restraint during the electrofusion process. Infinitely variable grip clamps to suit any combination of sizes, 110-225mm. Quick tightening operation, lightweight & easy to use.</p>	29144.4300.009
Strap Clamps	Code
<p>Used to prevent movement during the weld process. The PLASSON Strap Clamp, a convenient, flexible system for holding PE pipes steady during the electrofusion process. Does not assist with rerounding. For larger dimensions it is recommended to combine two or more Pipe Clamps (Strap Clamp).</p>	
<p>Strap Clamp 110-560mm 4 pipe clamps, 2 base bars, angled adaptor 22.5°, 45°, 90° & 180°</p>	29144.4300.023
<p>Ball Joint Single Ball Joint</p>	29144.4301.001
<p>Double Ball Joint</p>	29144.4301.002
<p>Strap Clamp 250-800mm With 2 fixed clamps, 2 clamps required</p>	29144.4300.021
<p>Strap Clamp 250-800mm Set Included in set: 2 complete clamps each with a pulling clamp, a fixed clamp and pulling shoes for couplers. Allows you to pull the coupler over the pipe and the opposite pipe into the coupler to complete the insertion.</p>	29144.4300.026
<p>Pipe Support Pipe support to 225mm</p>	29144.4601.003



Specialized Installation Tooling For PLASSON Products | Sujetadores para la instalación de productos PLASSON

Waste Water Saddle Installation Tools	Code
Waste Water Clamping & Cutting Tool Set 110 110mm X 45Deg fixed outlet saddle clamp kit. Mains pipe sizes DN160-DN315 Includes: - Saddle clamp unit - Coupon removal tool. Drill not included.	29144.4703.001 ■
Tool for Waste Water Saddle 160 160mm Flexible Outlet Saddle Clamp Kit. Main pipe sizes DN225-DN560 Includes: - Saddle clamp unit - Core drill kit	29144.4700.001 ■



Tension belt for Flex Restraint	Code
Flex Restraint installation clamp (160-1200)	29144.4704.002



Clamping Tool For Sensor Adaptor	Code
Clamping Tool For Sensor Adaptor DN110-DN1200	29144.4706K000
Clamping Tool For Sensor Adaptor DN110-DN1200 without strap	29144.4706K001



Sujetadores para la instalación de tomas

Large Bore Saddles Installation Tools | Sujetadores para la instalación de tomas simples/bridadas de gran diámetro / Ramales PLASSON

To install a PLASSON Large Bore Saddle the following are required:

1. A Clamp Kit to suit the outlet size of the saddle.
2. A Strap Kit for outlet sizes DN200 - DN400.
3. A Core Cutter to core the saddle after welding.
4. A Drill/Motor to operate the Core Cutter.

Clamp Kits	Code
Saddle outlets DN90 - DN160 Includes: <ul style="list-style-type: none"> - Splittable Plates: DN90, 110, 125 & 160 - Pressure Test Spigot Removal Tool - Straps - Rounding Ring - Transport Case 	29144.4701.003 ■
Saddle outlet DN200/DN180 - Includes: <ul style="list-style-type: none"> - Splittable Plate: DN200/DN180 - Rounding Ring - Transport Case - Strap kit required 	29144.4701.201 ■
Saddle outlet DN225/DN250 - Includes: <ul style="list-style-type: none"> - Splittable Plate: DN250 - Rounding Ring - Transport Case - Strap kit required - Rerounding adaptor required for DN225 201 2043 	29144.4701.251 ■
Saddle outlet DN 315/DN 280 - Includes: <ul style="list-style-type: none"> - Splittable Plate: DN 315/DN 280 - Transport Case - Strap kit required - Pressing plate 	29144.4701.315
Saddle outlet DN 400/DN355 - Includes: <ul style="list-style-type: none"> - Splittable Plate: DN 400/DN355 - Transport Case - Strap kit required - pressing plate 	29144.4701.400



Strap Kit	Code
Suitcase with straps and ratchets for PLASSON saddle clamp for xl, xxl plates outlets 180-400, pipes 315-1200: <ul style="list-style-type: none"> - 3x Straps - 3x Ratchets - Torque wrench - Pressure Test Spigot Removal Tool - Transport Case 	29144.4701.009



Rounding Adaptor	Code
DN250 to DN225 Rerounding Adaptor - Use with clamp kit	29141.4701.058

Support Bar	Code
Support Bar for Large Bore Repair Saddle DN250 – DN900 Use in conjunction with DN160 Saddle Outlet Kit	29142.4701.071

Saddle Pressing Tool	Code
Pressing Tool 225mm/SDR17 for lightFit Saddle	29142.4701.066



Saddle Clamping Tool	Code
Clamping Plate 225mm/SDR17 Splittable, for LightFit Saddle	29142.4701.226

Large Bore Saddles Installation Tools Cont.

Core Cutters	Code
Saddle outlet DN90 - DN160 - Includes: 1x 2" 1x DN90 core cutter 1x DN110 core cutter 1x DN125 core cutter 1x DN160 core cutter 1x Centre Drill 1x Drill chuck connector 1x Connector for SDS-Plus 1x Transport Case	29144.4702.003
Saddle outlet DN180, SDR11 DN180 Core Cutter, Borehole 143mm Includes Drill Adaptor and Case	29144.4702.143
Saddle outlet DN200, SDR11 DN200 Core Cutter, Borehole 159mm Includes Drill Adaptor and Case	29144.4702.159
Saddle outlet DN225, SDR11 DN225 Core Cutter, Borehole 179mm Includes Drill Adaptor and Case	29144.4702.179
Saddle outlet DN250, SDR11 DN250 Core Cutter, Borehole 199mm Includes Drill Adaptor and Case	29144.4702.199
Saddle outlet DN315, SDR11 DN315 Core Cutter, Borehole 251mm Includes Drill Adaptor and Case	29144.4702.251
Saddle outlet DN355, SDR11 DN355 Core Cutter, Borehole 283mm Includes Drill Adaptor and Case	29144.4702.283
Saddle outlet DN400, SDR11 DN400 Core Cutter, Borehole 319mm Includes Drill Adaptor and Case	29144.4702.319



Pressure Test Pump	Code
Pressure test pump with adapter for PLASSON large bore saddles	29144.4701.005

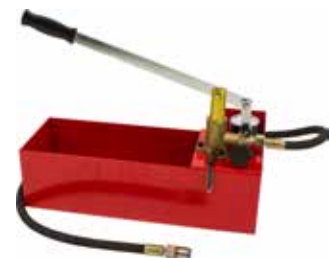

Tools for Drilling | Herramientas para perforación de tomas simples/bridadas de gran diámetro/Ramales PLASSON

Saddles with outlets DN90 – DN225 use a hand operated drill.

Saddles with a DN250 outlet can use either a hand operated drill or a motor mounting clamp and motor.

Saddles with outlets DN315 - DN400 use a motor mounting clamp and motor.

The same motor can be used on all outlets.

Drills - Motor	Code
DN90 - DN250 Outlets. BE75-X3 Quick	29144.4702.999

Saddle Drilling Equipment	Code
---------------------------	------

A complete tool consists of: Basic kit, clamping ring and core cutter.
So, the user must choose the components he needs when he orders.

Basic Kit	29144.4702.911
Clamping Ring DN250	29142.4702.030
Clamping Ring DN280	29142.4702.035
Clamping Ring DN315	29142.4702.029
Clamping Ring DN355	29142.4702.034
Clamping Ring DN400	29142.4702.028
Core cutter DN250 SDR11	29141.4704P199
Core cutter DN280 SDR11	29141.4704P233
Core cutter DN315 SDR11	29141.4704P251
Core cutter DN355 SDR11	29141.4704P283
Core cutter DN400 SDR11	29141.4704P319



Hot Tapping Tool | Herramientas para tomas en carga de grandes diámetros

Hot Tapping	Code
Core cutter 250mm	29141.4704P199
Core cutter 280mm	29141.4704P233
Core cutter 315mm	29141.4704P251
Core cutter 355mm	29141.4704P283
Core cutter 400mm	29141.4704P319
Hot Tapping Tool ISO Flange DN150 with 230V Motor	29144.4705.001
Hot Tapping Tool ISO Flange DN150 with 110V Motor	29144.4705.002
Hot Tapping Tool ISO Flange DN150 with 230V Hydraulic Motor excluding hydraulic pump	29144.4705.H001
Hydraulic Pump with Gasoline Engine	29142.4705.300

The tools consists of Motor, Pressure compartment, an Adapter (if necessary) and a core cutter. All components must be ordered separately:

PN16 Compartment DN150	29142.4705.001
PN16 Compartment DN200	29142.4705.006
PN16 Compartment DN250	29142.4705.002
PN16 Compartment DN300	29142.4705.007
PN16 Compartment DN400	29142.4705.004
Adapter DN150 -> DN100	29142.4705.100
Adapter DN150 -> DN80	29142.4705.101



Hot Tapping Tool for Large Bore Saddles

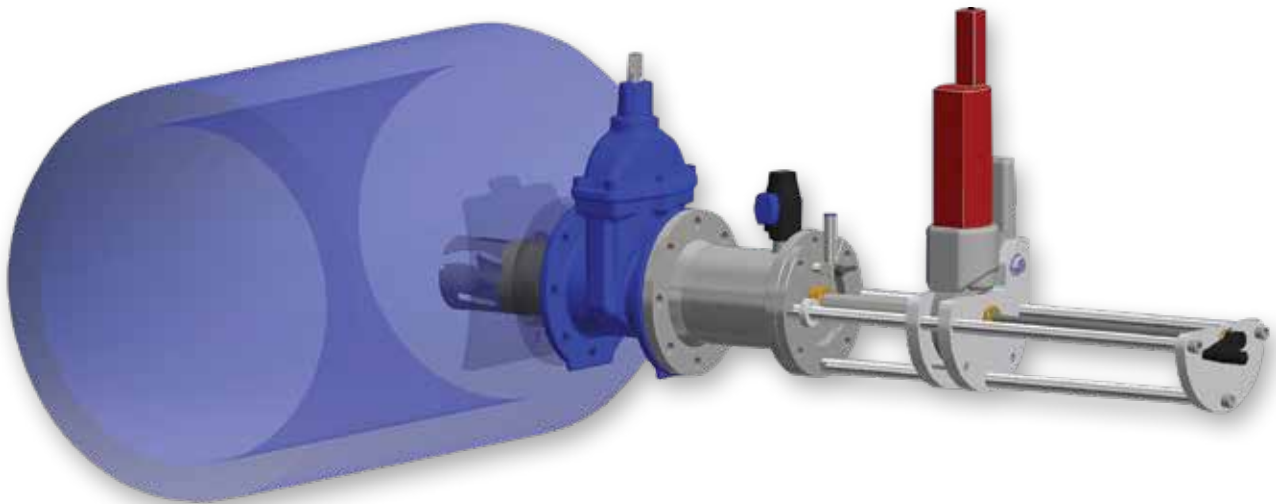



Take good care of your PLASSON control box



It is recommended that control boxes are serviced every 12 months or 200 hours of operation

Frequent servicing of your control box reduces the risk of operational problems interrupting the work flow and costing you money.

A standard service includes:

- Recalibration
- Installation of latest software
- Inspection and testing of all components
- Calibration Certificate

